

TILLER FF500

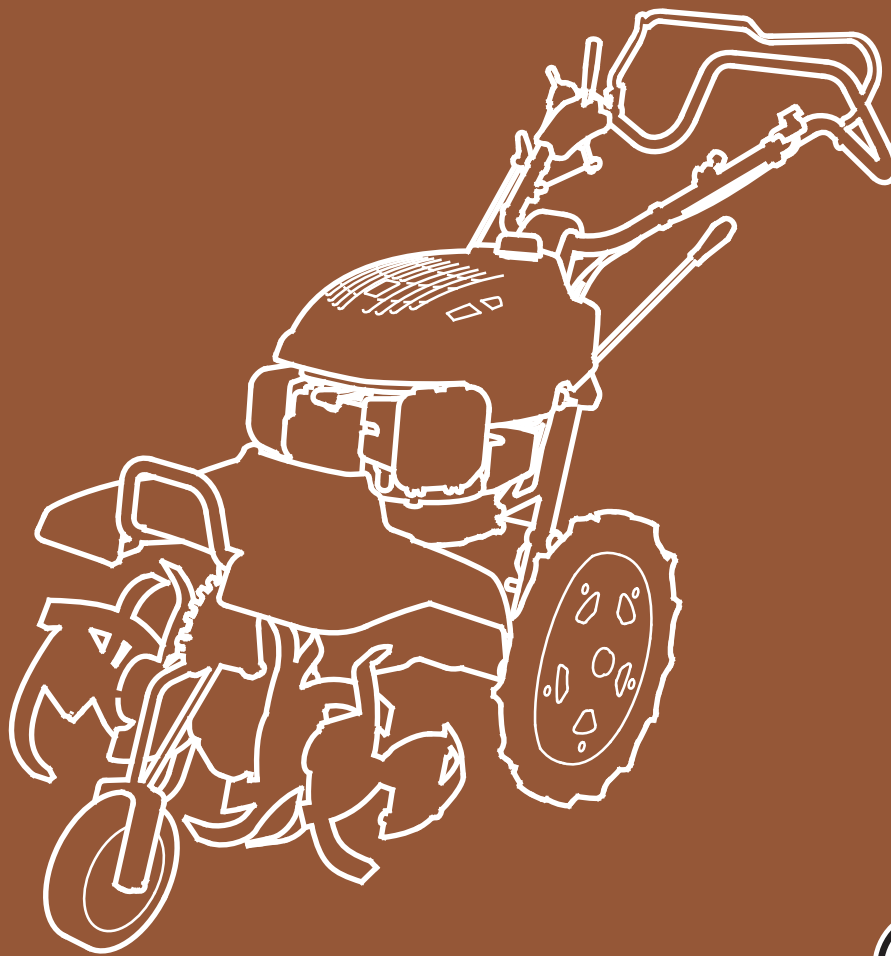

ECOLOGY CONSCIOUS TECHNOLOGY

**OWNER'S MANUAL
MANUEL DE L'UTILISATEUR
BEDIENUNGSANLEITUNG
MANUAL DE EXPLICACIONES**

Honda FF500

OWNER'S MANUAL

MANUEL DE L'UTILISATEUR

BEDIENUNGSANLEITUNG

MANUAL DE EXPLICACIONES



ECOLOGY CONSCIOUS TECHNOLOGY

“e-SPEC” was originally created with our wish to “preserve nature for generations to come”.

Now it also symbolizes environmentally responsible technologies applied to Honda engines, power equipment, outboard engines, etc., and is to be used to identify those products which adopt the highest levels of environmental technologies developed by Honda.

Thank you for purchasing a Honda tiller.

This manual covers operation and maintenance of the FF500 tiller.

All information in this publication is based on the latest product information available at the time of printing.

Honda Motor Co., Ltd. reserves the right to make changes at any time without notice and without incurring any obligation.

No part of this publication may be reproduced without written permission.

This manual is considered a permanent part of the tiller and it must stay with the tiller if resold.

Pay special attention to statements preceded by the following words:

▲WARNING Indicates a strong possibility of severe personal injury or death if instructions are not followed.

CAUTION: Indicates a possibility of personal injury or equipment damage if instructions are not followed.

NOTE: Gives helpful information.

If a problem should arise, or if you have any questions about your tiller, consult an authorized Honda tiller dealer.

▲WARNING

The Honda tiller is designed to give safe and dependable service if operated according to instructions. Read and understand the Owner's Manual before operating the tiller. Failure to do so could result in personal injury or equipment damage.

CONTENTS

1. SAFETY INSTRUCTIONS	3
2. SAFETY LABEL LOCATIONS	8
CE mark and noise label locations	9
3. COMPONENT IDENTIFICATION	10
4. PRE-OPERATION CHECK	12
5. STARTING THE ENGINE	19
• High altitude operation	22
6. TILLER OPERATION	23
7. STOPPING THE ENGINE	32
8. MAINTENANCE	34
9. CLEANING AFTER USE	53
10. TRANSPORTING/STORAGE	54
11. TROUBLESHOOTING	57
12. SPECIFICATIONS	60
13. MAJOR Honda DISTRIBUTOR ADDRESSES IN EUROPE	61

1. SAFETY INSTRUCTIONS

⚠ WARNING

To ensure safe operation —

For your safety and the safety of others, pay special attention to these precautions:



- Honda tiller is designed to give safe and dependable service if operated according to instructions. Read and understand the Owner's Manual before operating the tiller. Failure to do so could result in personal injury or equipment damage.

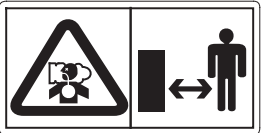

- Exhaust gas contains poisonous carbon monoxide. Never run the tiller in an enclosed area. Be sure to provide adequate ventilation.



- The rotating tines are sharp and they turn at high speed. Accidental contact can cause serious injury.
 - Keep your hands and feet away from the tines while engine is running.
 - Stop the engine and disengage the clutch before inspection or maintenance of tines.
 - Disconnect the spark plug cap to prevent any possibility of accidental starting. Wear heavy gloves to protect your hands from the tines when cleaning the tines or when inspecting or replacing the tines.

Operator responsibility

- Keep the tiller in good operating condition. Operating a tiller in poor or questionable condition could result in serious injury.
- Be sure all safety devices are in working order and warning labels are in place. These items are installed for your safety.
- Be sure the safety covers (tine covers, fan cover and recoil starter cover) are in places.
- Know how to stop the engine and tines quickly in case of emergency. Understand the use of all controls.
- Keep a firm hold on the handlebars. They may tend to lift during clutch engagement.

▲WARNING

To ensure safe operation —

Operator responsibility

- Read the owner's manual carefully. Be familiar with the controls and their proper use of the tiller.
- Use the tiller for the purpose it is intended that is, cultivating the soil. Any other use could be dangerous or damage the equipment, especially never use it to cultivate soil containing rocks, stones, wires and any other hard materials.
- Never allow children or people unfamiliar with this owner's manual to use the tiller. Local regulations may restrict the age of the operator.
- Before each use, visually inspect the tiller including parts for any wear, damage and looseness. If necessary, replace the damaged parts as an assembly.
- Keep in mind that the owner or user is responsible for accidents or damage, occurring to other people or their property. In the event of hire use, be sure that operational explanations are given in the presence of the user.
- Keep your hands and feet away from the tines while the engine is running.
- Allowing anyone to operate this tiller without proper instruction may result in injury.
- Wear sturdy, full-coverage footwear. Operating this tiller barefoot or with open toe shoes or sandals increases your risk of injury.
- Dress sensibly. Loose clothing may get caught in moving parts, increasing your risk of injury.
- Be alert. Operating this tiller when you are tired, ill or under the influence of alcohol or drugs may result in serious injury.
- Keep all persons and pets away from the tilling area.
- Be sure drag bar is in place and properly adjusted.
- Do not change the engine governor settings or overspeed the engine.
- Start the engine carefully according to the instructions in this manual, keeping your feet away from the tines.
- When starting the engine, keep your feet away from the tines.
- Avoid operating the tiller at night or in a bad weather of poor visibility, because there is much possibility of accident.
- Walk, never run during operation.
- When taking backward steps during operation, pay special attention to people and obstacles behind the operator.
- Before transporting or hoisting the tiller, make sure that the engine is stopped.

▲WARNING

To ensure safe operation —

Operator responsibility

- Stop the engine in the following cases:
 - Whenever you leave the tiller unattended.
 - Before refueling
- When stopping the engine, move the throttle lever to the LOW position, then turn the engine switch OFF. If the fuel valve is equipped on the tiller, be sure to turn the fuel valve OFF.
- Keep all nuts, bolts and screws tight to be sure the tiller is in safe working condition. Regular maintenance is an essential aid to user's safety and retaining a high level of performance.
- Never store the tiller with gasoline in the tank inside a building where fumes may reach an open flame, spark or high temperature source.
- Allow the engine to cool before storing in any enclosure.
- To reduce the fire hazard, keep the tiller especially the engine, muffler, the gasoline storage area as well, free of grass, leaves, or excessive grease.
Do not leave containers of vegetable matters in or near a building.
- If the fuel tank has to be drained, this should be done outdoors, with a cold engine.
- Replace the worn or damaged parts for safety.

Child safety

- Keep children indoors and supervised at all times when any outdoor power equipment is being used nearby. Young children move quickly and are attracted especially to the tiller and the tilling activity.
- Never assume children will remain where you last saw them. Be alert and turn the tiller off if children enter the area.
- Children should never be allowed to operate the tiller, even under adult supervision.

Thrown object hazard

Objects hit by the rotating tines can be thrown from the tiller with great force, and may cause serious injury.

- Before tilling, clear the tilling area of sticks, large stones, wire, glass, etc. Till only in daylight.
- Always inspect the tiller for damage after striking a foreign object. Repair or replace any damaged parts before continuous use.
- Pieces thrown from worn or damaged tines can cause serious injury. Always inspect the tines before using the tiller.

▲WARNING

To ensure safe operation —

Fire and burn hazard

Gasoline is extremely flammable, and gasoline vapor can explode. Use extreme care when handling gasoline. Keep gasoline out of reach of children.

- Add fuel before starting the engine. Never remove the cap of the fuel tank or add gasoline while the engine is running or when the engine is hot.
- Refuel in a well-ventilated area with the engine stopped.
- Refuel outdoors only and do not smoke while refueling or handling fuel.
- Allow the engine to cool before refueling. Fuel vapor or spilled fuel may ignite.
- The engine and exhaust system become very hot during operation and remain hot for a while after stopping. Contact with hot engine components can cause burn injuries and can ignite some materials.
- Avoid touching a hot engine or exhaust system.
- Allow the engine to cool before performing maintenance or storing the tiller indoors.
- Tighten all fuel tanks and container caps securely.
- Store fuel in containers specifically designed for this purpose.
- If gasoline is spilled, do not attempt to start the engine but move the tiller away from the area of spillage and avoid creating any source of ignition until gasoline vapors have dissipated.

▲WARNING

To ensure safe operation —

Carbon monoxide poisoning hazard

Exhaust contains poisonous carbon monoxide, a colorless and odorless gas. Breathing exhaust can cause loss of consciousness and may lead to death.

- If you run the engine in an area that is confined or even partially enclosed, the air you breathe could contain a dangerous amount of exhaust gas. To keep exhaust gas from building up, provide adequate ventilation.
- Replace faulty muffler.
- Do not operate the engine in a confined space where dangerous carbon monoxide fumes can collect.

Operation on slope

- When tilling on slopes, keep the fuel tank less than half full to minimize fuel spillage.
- Till across the slope (at equally spaced intervals) rather than up and down it.
- Be very careful when changing the direction of the tiller on a slope.
- Do not use the tiller on a slope of more than 10°.

The maximum safe grade angle shown is for reference purpose only and should be determined according to the type of the tool. Before starting the engine, check that the tiller is not damaged and in good condition. For your safety and safety of others, exercise extreme care when using the tiller on up or down hill.

2. SAFETY LABEL LOCATIONS

These labels warn you of potential hazards that can cause serious injury. Read the labels and safety notes and precautions described in this manual carefully.

If a label comes off or becomes hard to read, contact your Honda dealer for a replacement.

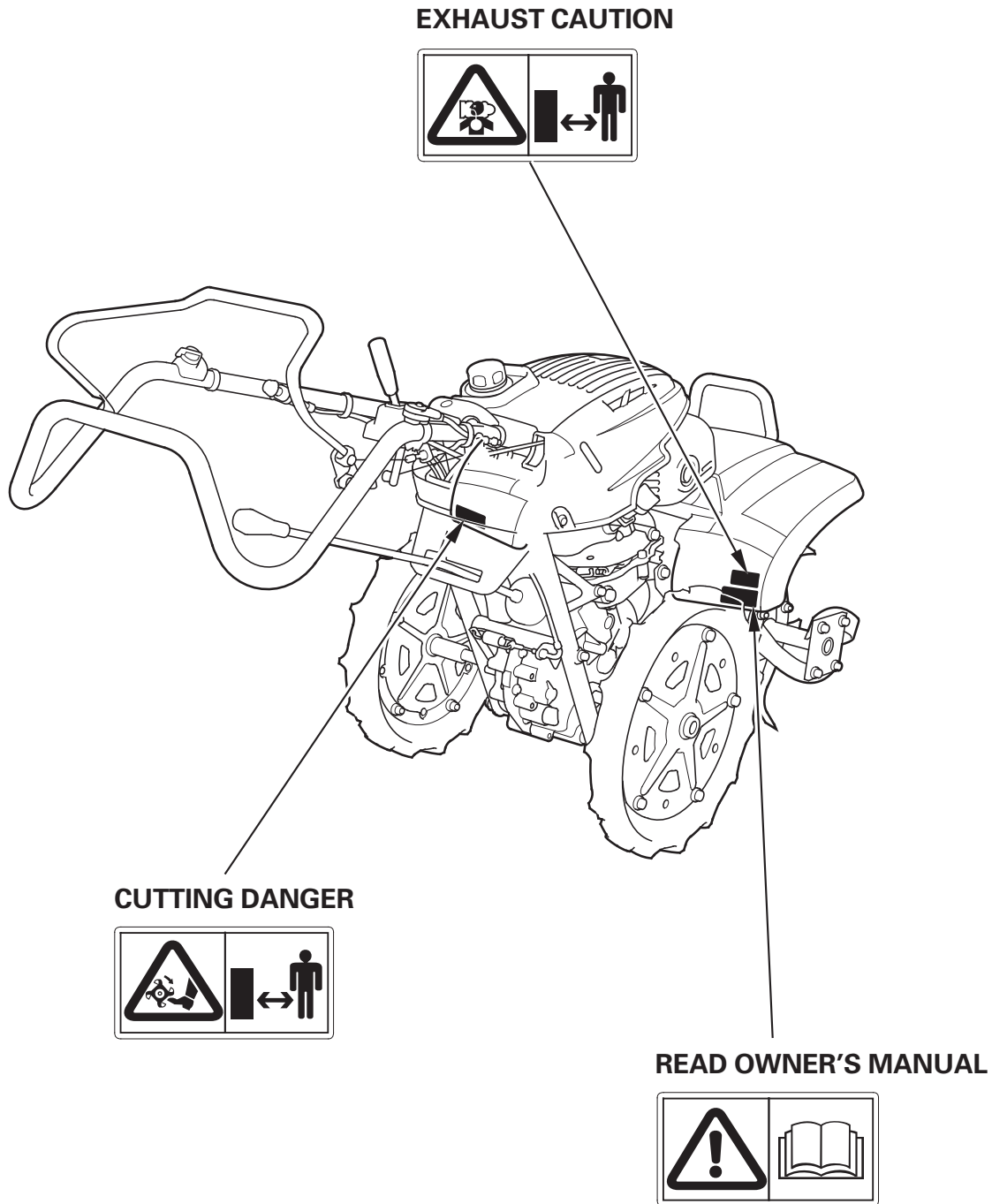

CE mark and noise label locations

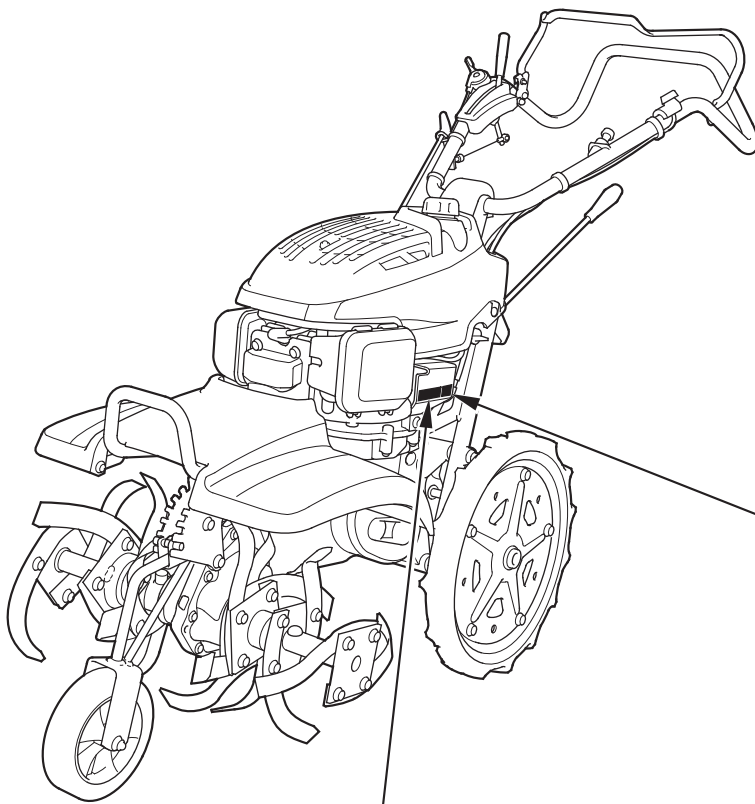

NOISE LABEL

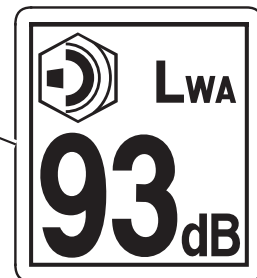

CE MARK

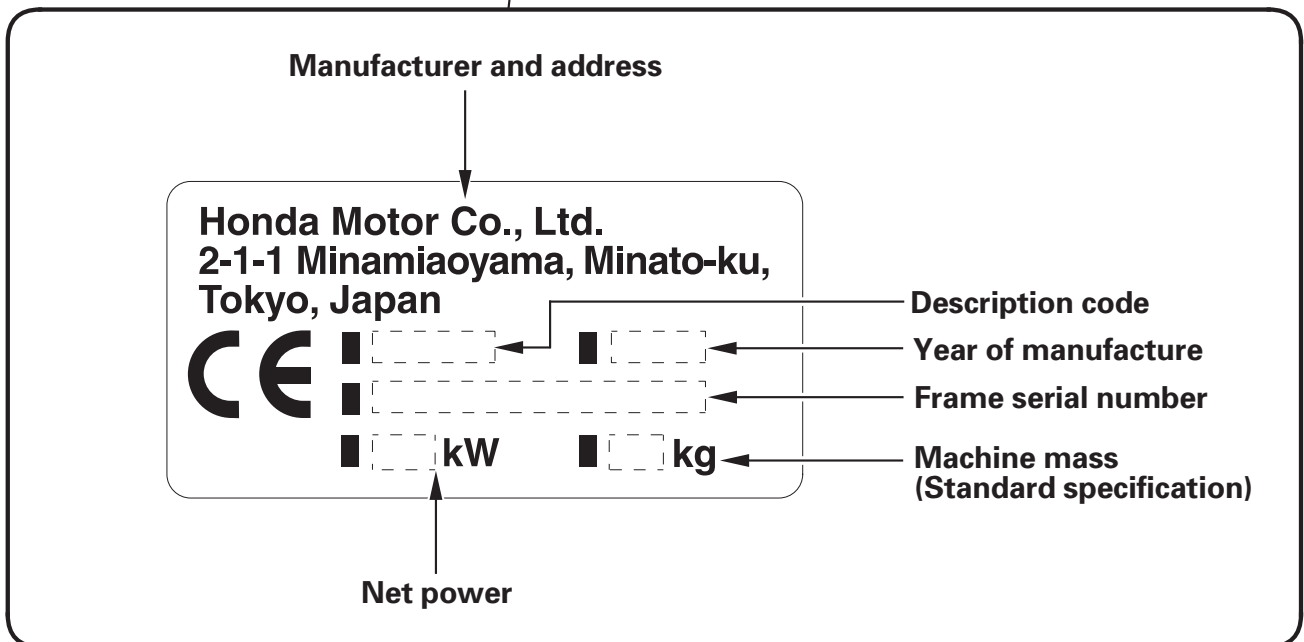

3. COMPONENT IDENTIFICATION

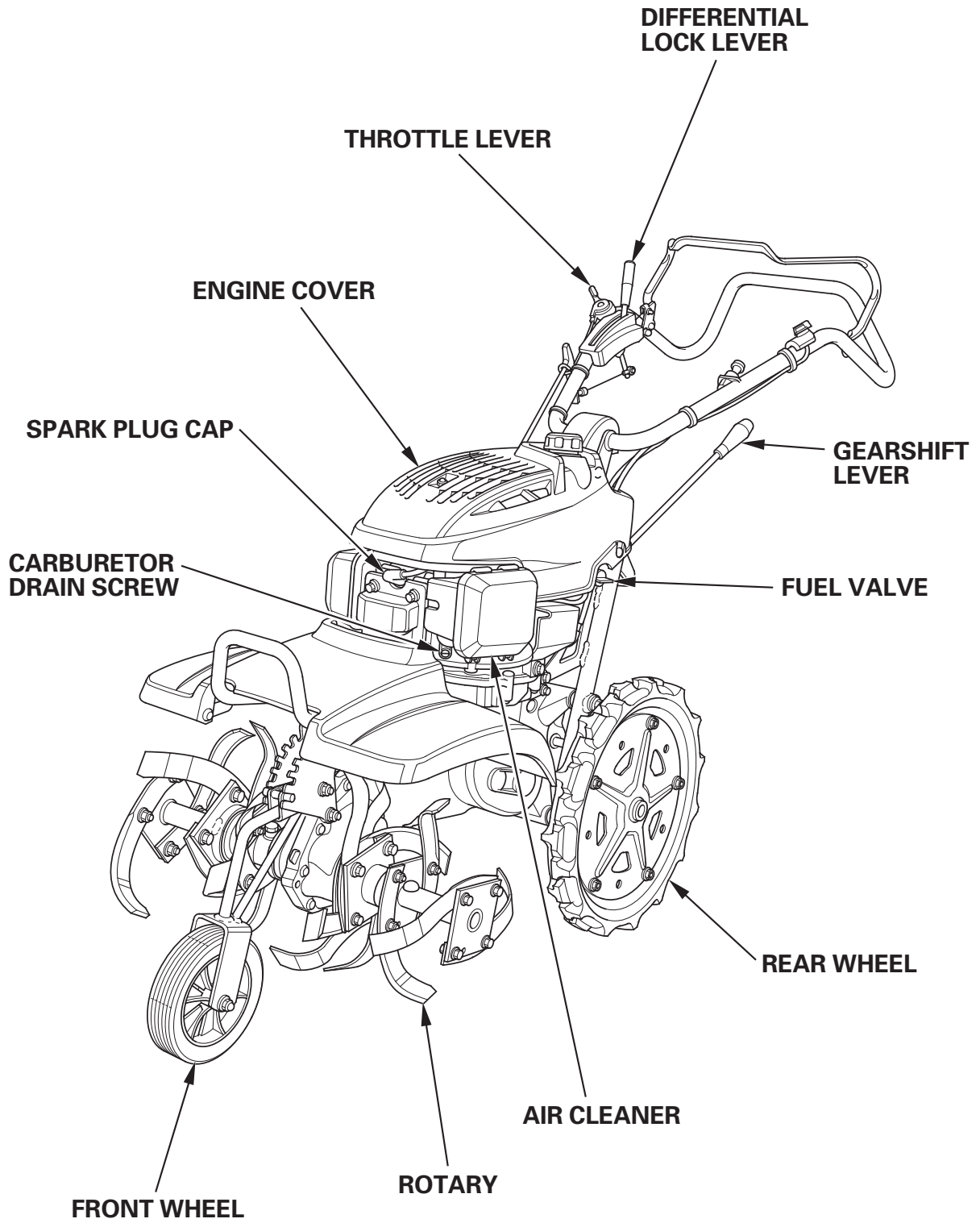

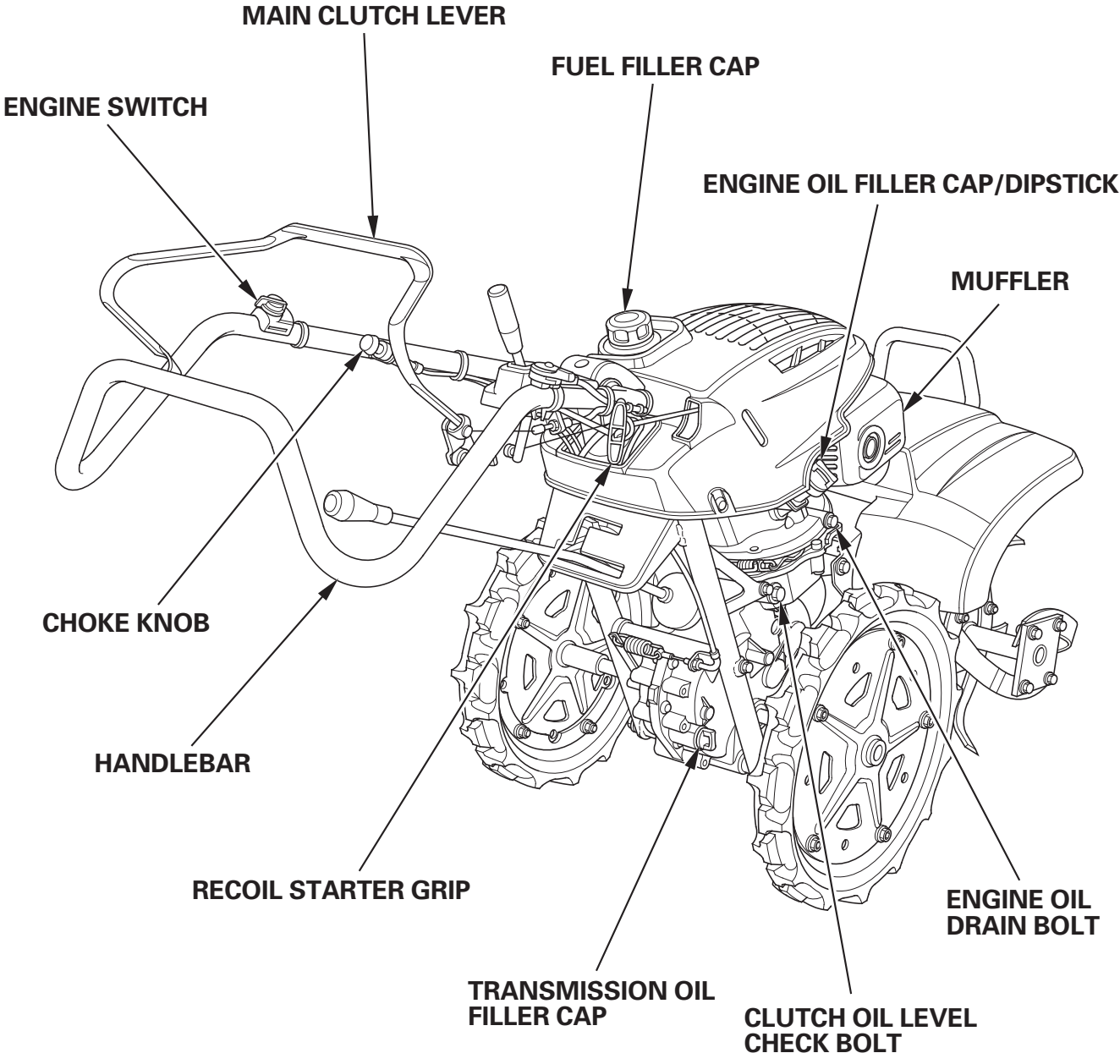

4. PRE-OPERATION CHECK

▲WARNING

Place the tiller on a firm level surface and hold the tiller level (i.e. with the rotary tines and rear wheels set on the ground). Stop the engine before starting service of the tiller. Servicing the tiller on an unstable surface of the ground or without stopping the engine can cause injury and/or equipment damage.

Daily inspection and service of tiller is essential for safe and reliable operation. Perform the following check before operation.

1. Tiller outside

Aren't the fuel and engine oil leaking?

Isn't there any flammable material (dust, straw, etc.) around the engine?

2. Control lever function

Does the lever operate smoothly?

Is there the specified amount of free play at the tip of the lever (page 43 through 45)?

3. Wiring and cables

Isn't the insulation of each wire and cable torn or cut?

Is there any wire or cable pinched by the neighboring parts?

4. Engine operation

- Start the engine. Is there any abnormal sound from the engine?(See pages 19 through 21 for starting procedure.)
- Does the engine stop securely by operating the engine switch?(See pages 32 and 33 for stopping procedure.)
- If you notice any other abnormal symptoms, consult with your authorized Honda dealer promptly.

5. Engine oil

CAUTION:
Running the engine with insufficient oil can cause serious engine damage.

1. Stop the engine and place the tiller on the level ground with rear wheels and tines.
2. Place a 60 mm (2.4 in) thick block under the rear wheels as shown.
3. Remove the oil filler cap/dipstick and wipe the dipstick clean.
4. Insert the dipstick into the oil filler neck, but do not screw it in.
5. If the oil level is low, fill up to the upper limit mark with the recommended oil.

Use 4-stroke motor oil that meets or exceeds the requirements for API service classification SE or later (or equivalent). Always check the API service label on the oil container to be sure it includes the letters SE or later (or equivalent).

SAE 10W-30 is recommended for general use. Other viscosities shown in the chart may be used when the average temperature in your area is within the indicated range.

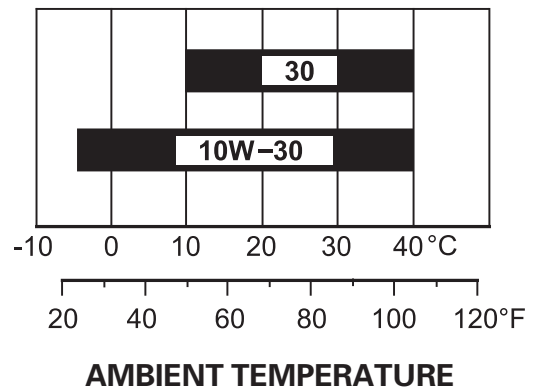
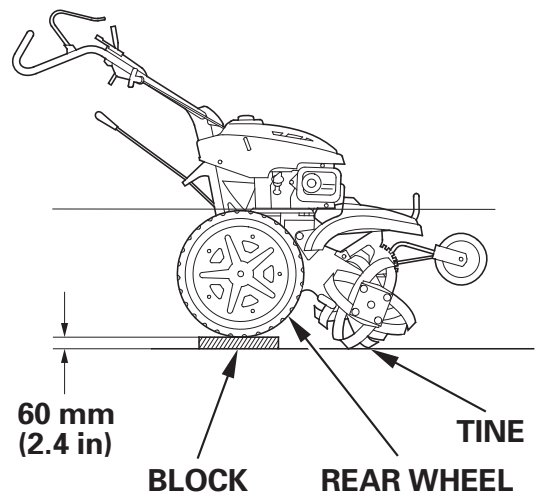

CAUTION:
Using nondetergent oil or 2-stroke engine oil will shorten the engine's service life.

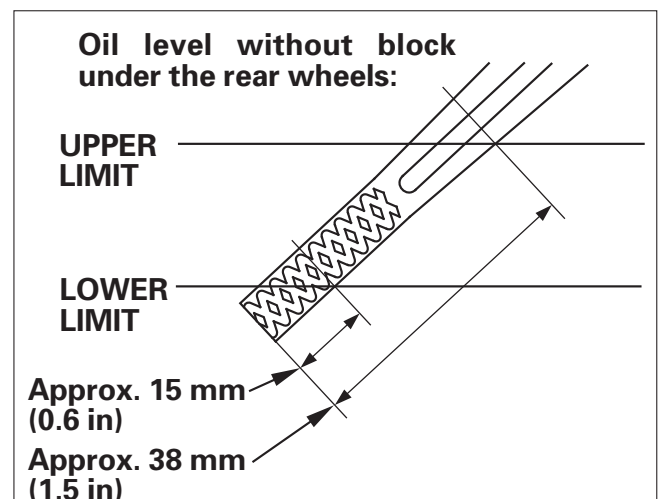
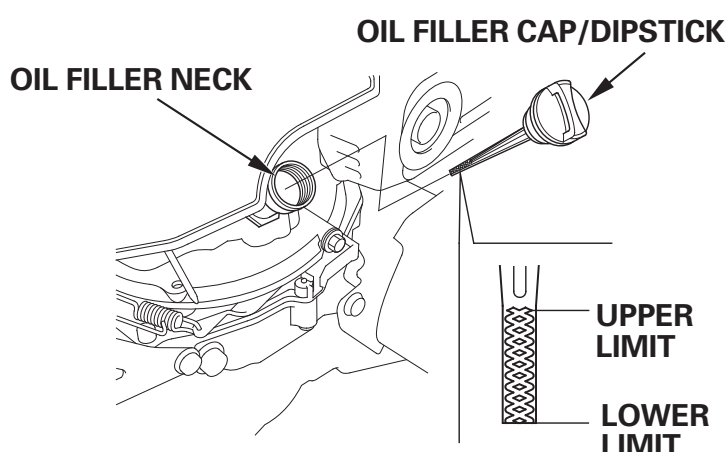

6. Air cleaner

CAUTION:

Never run the engine without the air cleaner. Rapid engine wear will result.

1. Push the latch tabs and pull the air cleaner cover out of the air cleaner case, then disengage the lower locking tabs from the air cleaner case and remove the air cleaner cover.
2. Check the air cleaner for dirt or obstruction of the element, clean the element if necessary (page 38).

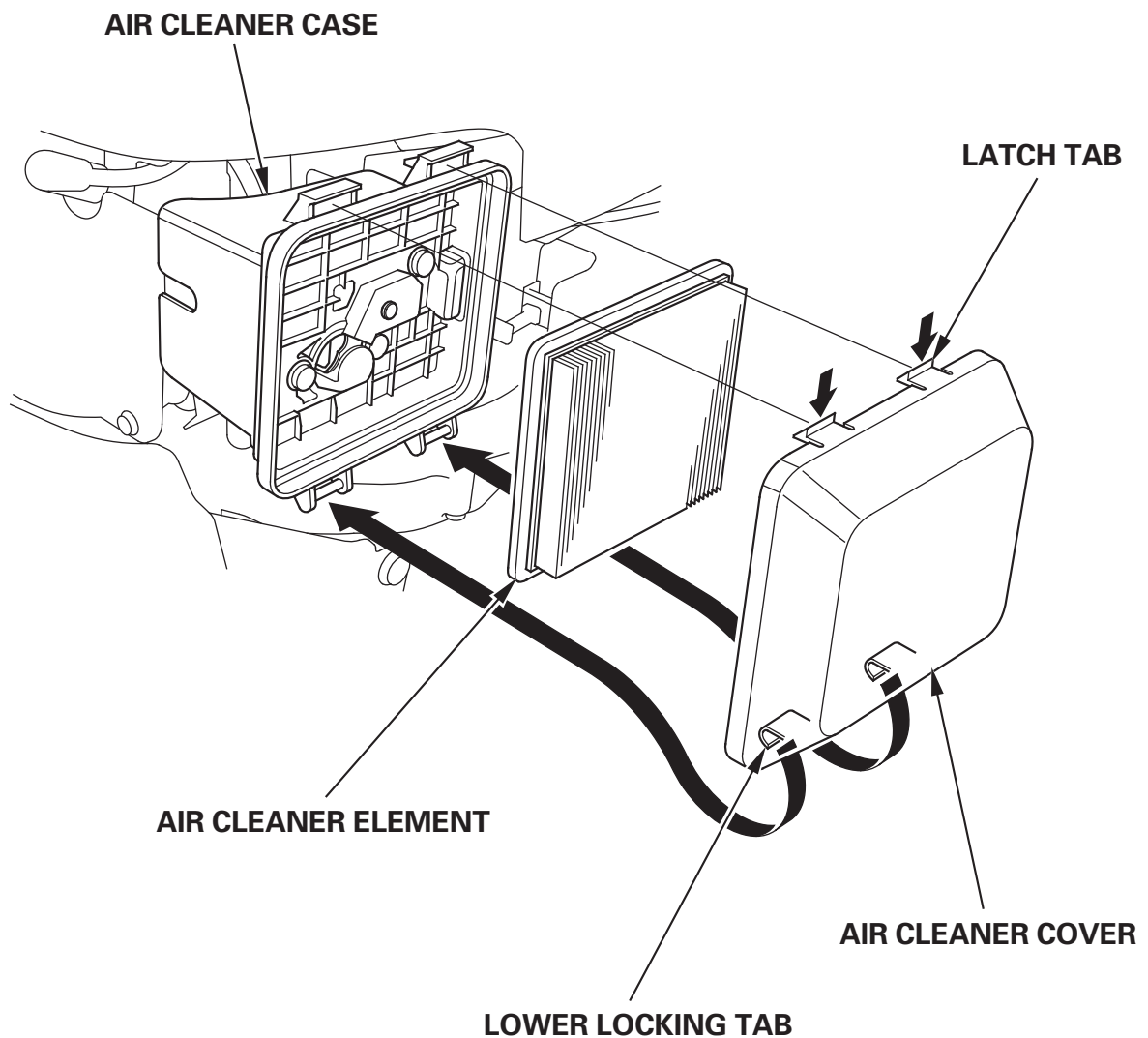

7. Fuel

Stop the engine and place the tiller on the level ground with rear wheels and tines.

Check the fuel level, and refill the tank if the fuel level is low.

Use automotive unleaded gasoline with a Research Octane Number of 91 or higher (a Pump Octane Number of 86 or higher).

Never use stale or contaminated gasoline or an oil/gasoline mixture. Avoid getting dirt or water in the fuel tank.

▲WARNING

- **Gasoline is extremely flammable and is explosive under certain conditions.**
- **Refuel in a well-ventilated area with the engine stopped. Do not smoke or allow flames or sparks in the area where the engine is refueled or where gasoline is stored.**
- **Do not overfill the fuel tank (there should be no fuel above the upper limit mark). After refueling, make sure the tank cap is closed properly and securely.**
- **Be careful not to spill fuel when refueling. Spilled fuel or fuel vapor may ignite. If any fuel is spilled, make sure the area is dry before starting the engine.**
- **Avoid repeated or prolonged contact with skin or breathing of vapor. KEEP OUT OF REACH OF CHILDREN.**

After refueling, be sure to tighten the fuel filler cap firmly.

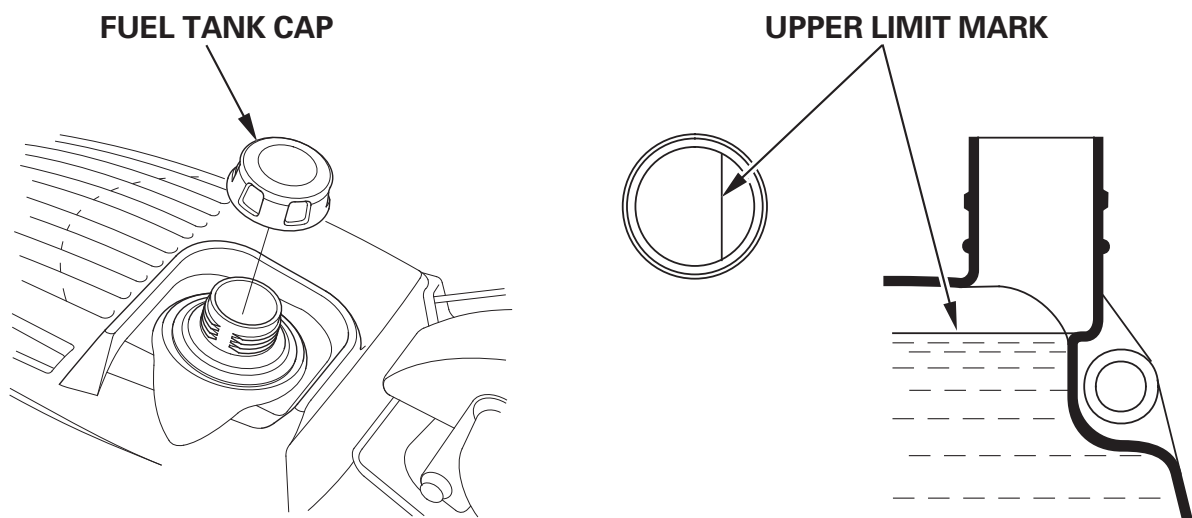

NOTE:

Gasoline spoils very quickly depending on factors such as light exposure, temperature and time.

In worst cases, gasoline can be contaminated within 30 days.

Using contaminated gasoline can seriously damage the engine (carburetor clogged, valve stuck).

Such damage due to spoiled fuel is disallowed from coverage by the warranty.

To avoid this please strictly follow these recommendations:

- Only use specified gasoline (see page 15).
- To slow deterioration, keep gasoline in a certified fuel container.
- If long storage (more than 30 days) is foreseen, drain fuel tank and carburetor (see page 56).

Gasolines containing alcohol

If you decide to use a gasoline containing alcohol (gasohol), be sure it's octane rating is at least as high as that recommended by Honda. There are two types of "gasohol": one containing ethanol, and the other containing methanol.

Do not use gasohol that contains more than 10% ethanol. Do not use gasoline containing methanol (methyl or wood alcohol) that does not also contain cosolvents and corrosion inhibitors for methanol.

Never use gasoline containing more than 5% methanol, even if it has cosolvents and corrosion inhibitors.

NOTE:

- Fuel system damage or engine performance problems resulting from the use of gasoline that contains alcohol is not covered under the warranty.

Honda cannot endorse the use of gasoline containing methanol since evidence of its suitability is as yet incomplete.

- Before buying gasoline from an unfamiliar station, first determine if the gasoline contains alcohol; if it does, find out the type and percentage of alcohol used.

If you notice any undesirable operating symptoms while using a gasoline that contains alcohol, or one that you think contains alcohol, switch to a gasoline that you know does not contain alcohol.

8. Tools and Attachments

To install a tool or attachment on the tiller, follow the instructions furnished with the tool or attachment. Ask your Honda dealer for advice if you encounter any problem or difficulty in installing a tool or attachment.

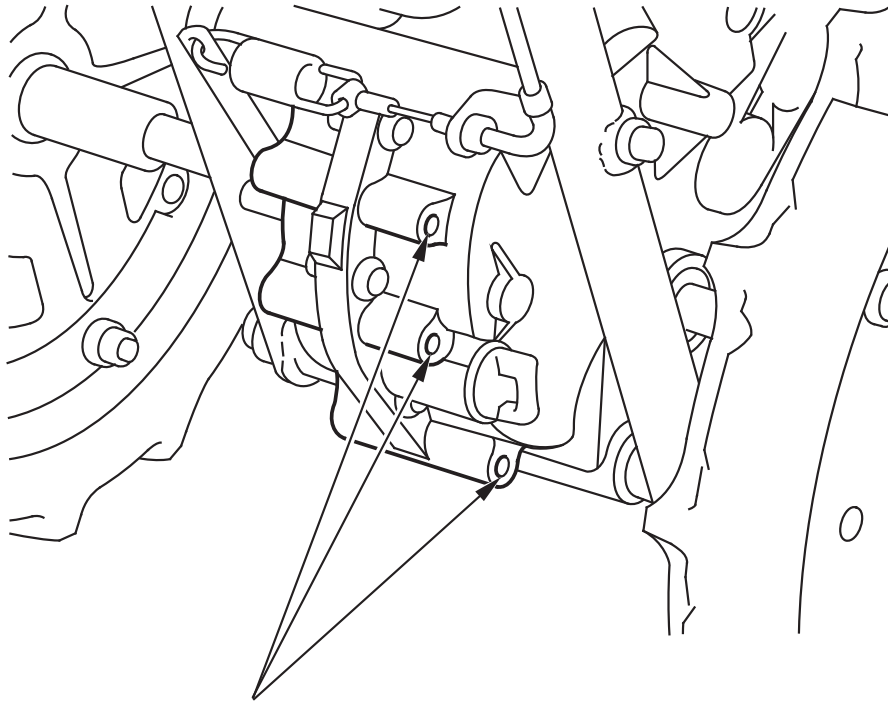

ATTACHMENT INSTALLATION POSITION

9. Wheel pin

Make sure that the wheel pin and retaining pin are securely installed.

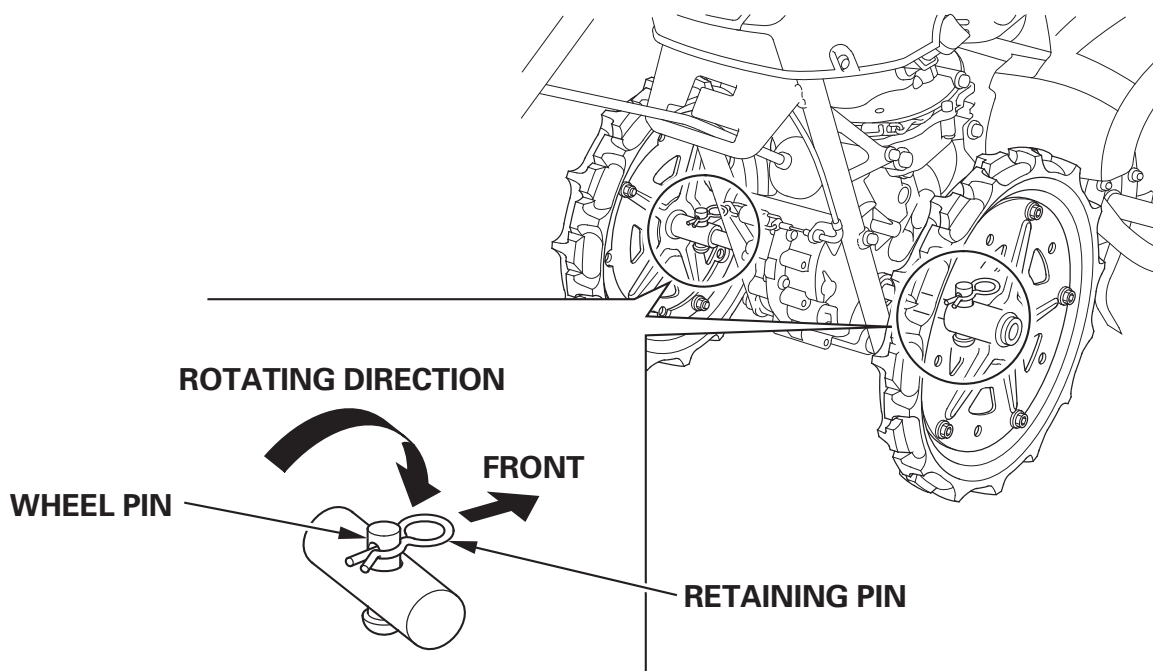

10. Tightening points

CAUTION:

- Carry out the check with the tiller on a level ground and the engine stopped.
- Wear thick gloves when checking or tightening the rotary part.

Check for looseness in fastened parts. Securely tighten all loose parts. Check for worn, bent or other damaged rotary tines.

Parts to be tightened

- Handlebar setting bolt
- Tine plate and rotary part

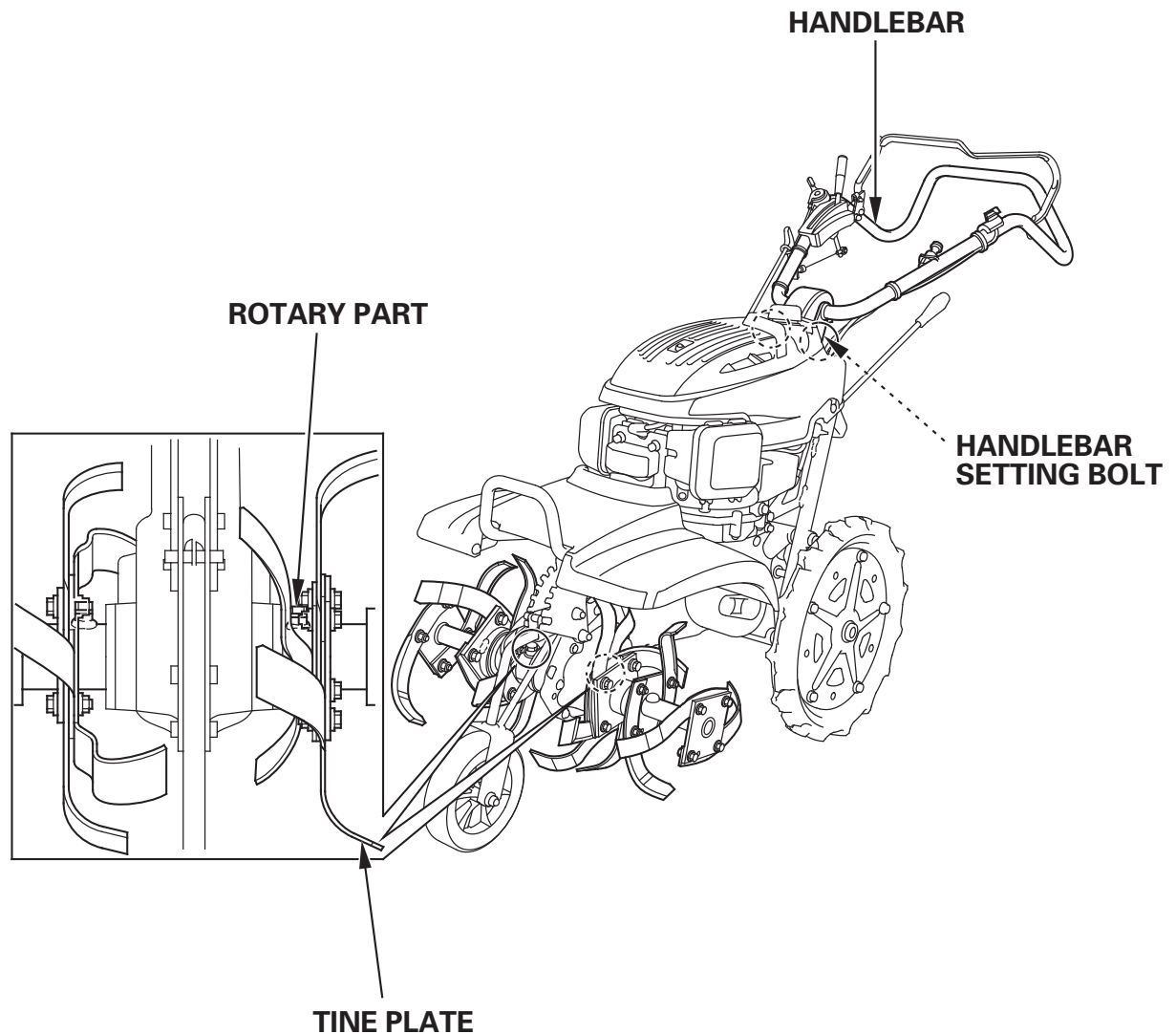

5. STARTING THE ENGINE

1. Turn the fuel valve to the ON position.

Before turning the fuel valve, make sure that the drain screw is tightened securely.

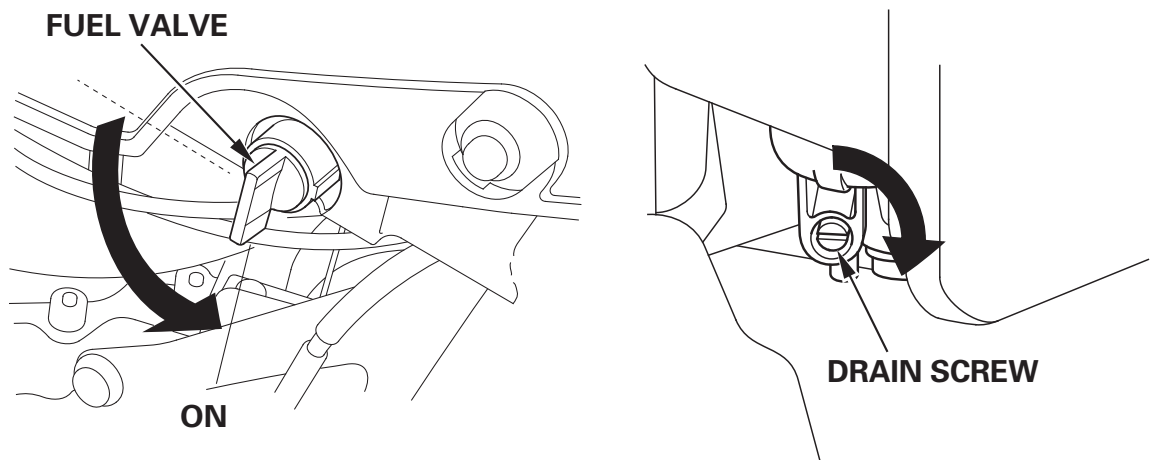

2. Make sure the main clutch lever is in the DISENGAGED position.

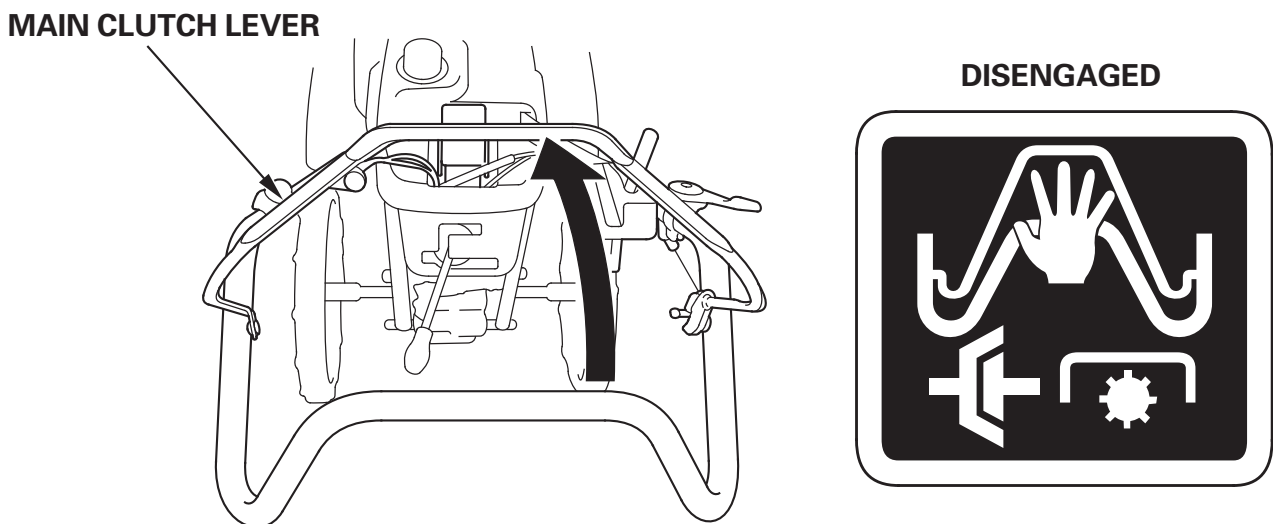

3. Make sure the gearshift lever is in the NEUTRAL position.

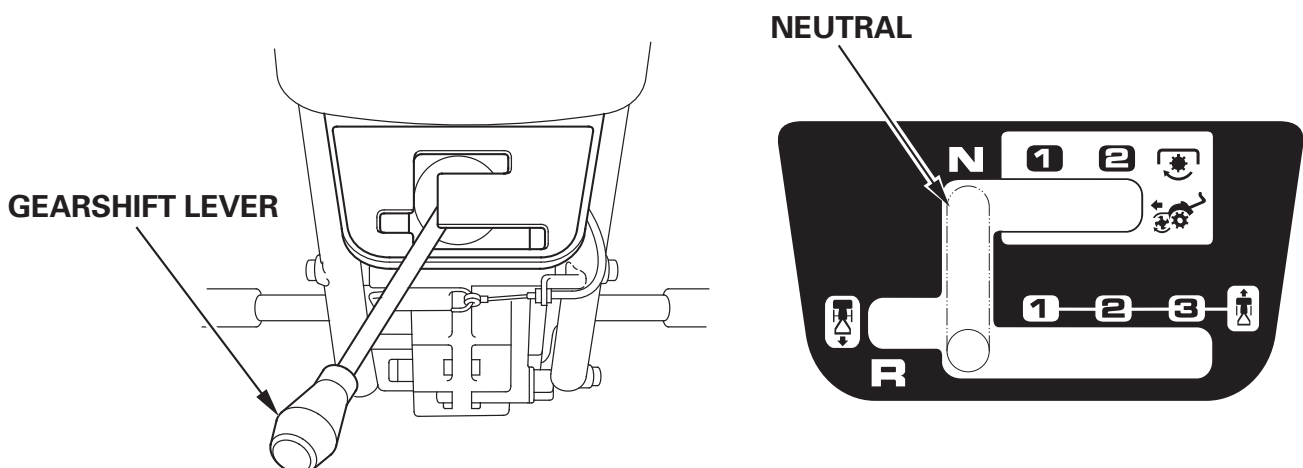

4. In cold weather and when the engine is cold, pull the choke knob to the CLOSE position.

NOTE:

Do not use the choke if the engine is warm or the air temperature is high.

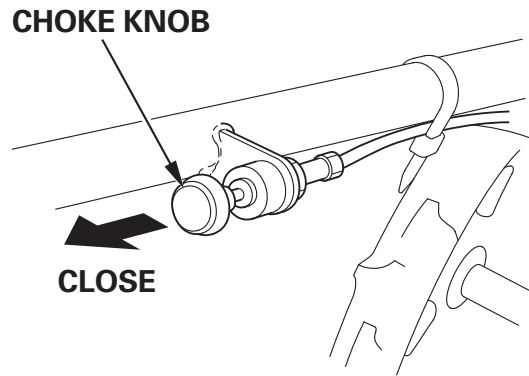
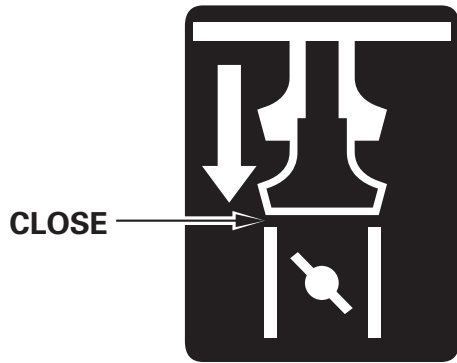

5. Turn the engine switch to the ON position.

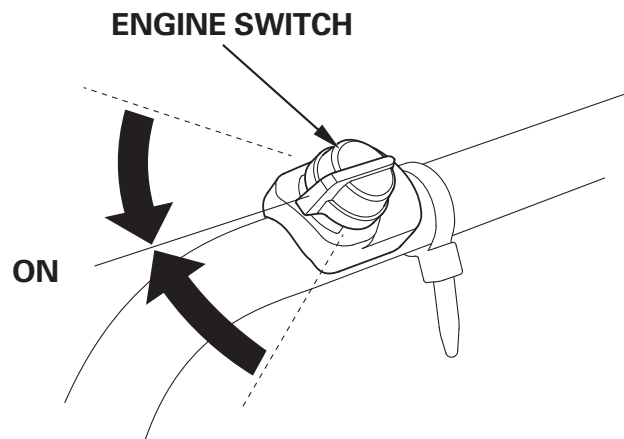
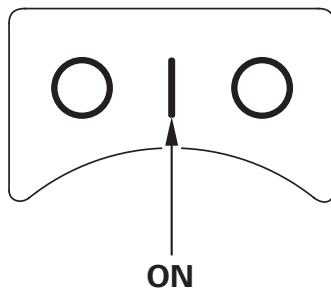

6. Align the mark "△" on throttle lever with the mark "●" (START position) as shown.

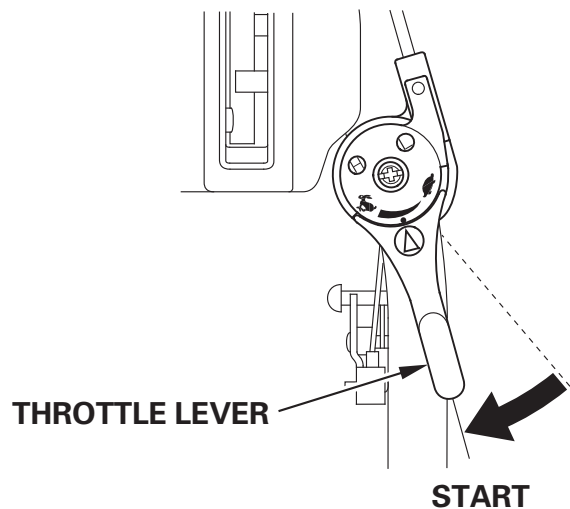
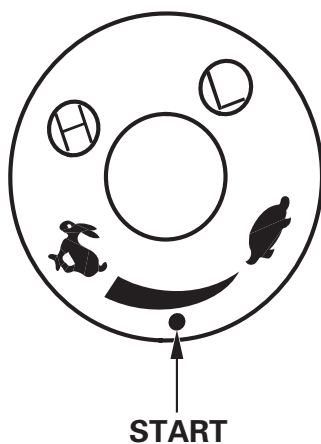

7. Pull the starter grip lightly until resistance is felt, then return the starter grip once. Hold the handlebar with your left hand and pull the starter grip briskly in the direction of the arrow as shown.

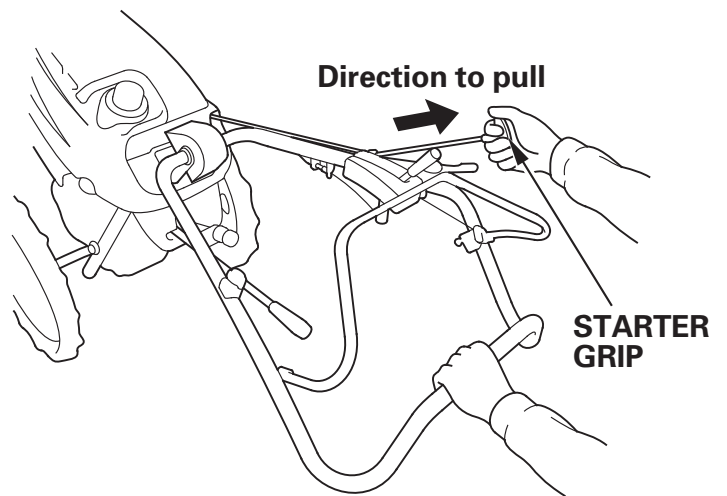

CAUTION:

Do not allow the starter grip to snap back. Return it gently to prevent damage to the starter.

8. Let the engine warm up for several minutes. If the choke knob has been pulled to the CLOSE position, push it gradually to the OPEN position as the engine warm up.

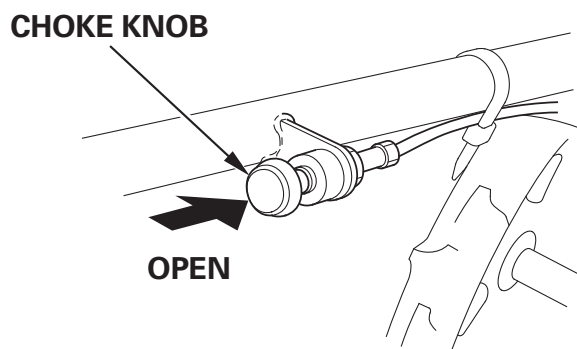
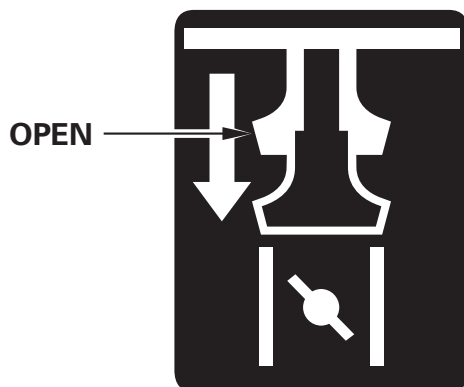

9. Adjust the throttle lever so that the engine speed is suitable.

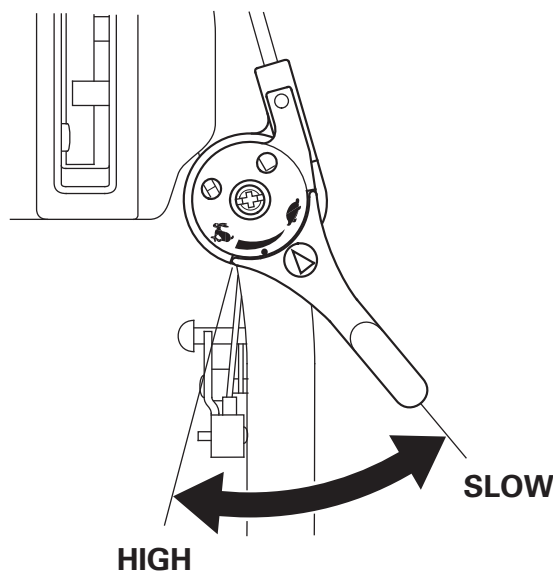

- **High altitude operation**

At high altitude operation, the standard carburetor air/fuel mixture will be excessively rich. Performance will decrease, and fuel consumption will increase.

High altitude performance can be improved by specific modification to the carburetor. If you always operate the tiller at altitude higher than 1,500 m (5,000 feet) above sea level, have your authorized Honda dealer perform these carburetor modifications.

Even with suitable carburetor jetting, engine horsepower will decrease approximately 3.5 % for each 300 m (1,000 foot) increase in altitude. The effect of altitude on horsepower will be greater than this if no carburetor modification is made.

CAUTION:

Operation of the tiller at an altitude lower than the carburetor is jetted for may result in reduced performance, overheating, and serious engine damage caused by an excessively lean air/fuel mixture.

6. TILLER OPERATION

Front wheel position adjustment

Front wheel height can be changed to adjust the tilling depth and to transport the tiller.

1. Set the tiller on a firm level ground and hold it securely by placing a suitable block under the transmission case.
2. Pull the front wheel beam forward to move the pin out of the groove and set it in the groove you want. Then, secure the pin in the position.

NOTE:

When the ground is too soft and the tiller gets into the ground, or when the ground is too hard, adjust the tilling depth in a shallow position.

- ①: For transportation Rotary ground clearance:
Approx. 30 mm (1.2 in)
- ②: Tilling depth: Approx. 20 mm (0.8 in)
- ③: Tilling depth: Approx. 60 mm (2.4 in)
- ④: Tilling depth: Approx. 120 mm (4.7 in)
- ⑤: Tilling depth: Approx. 160 mm (6.3 in)
- ⑥: Tilling depth: Approx. 200 mm (7.9 in)

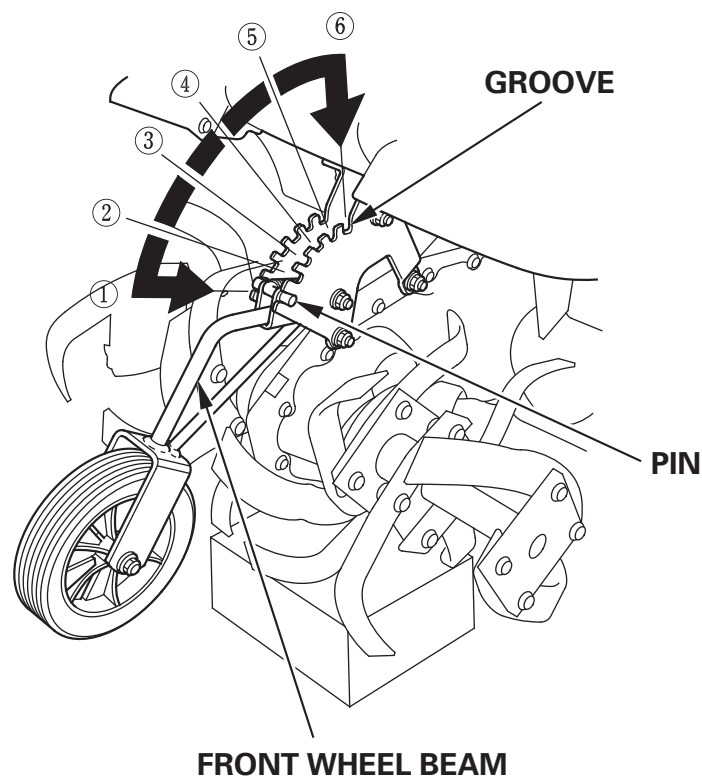

Tilling width adjustment

The tilling width is factory-set at the wide position. Remove the outer rotary to narrow the tilling width.

- Equalize the space difference between the tilling width and the rear wheel tread. Also equalize the space in the right and left sides.
- As the reverse-spinning outer rotary is removed to narrow the tilling width, the tilling is only in the normal direction of rotation.

▲WARNING

- Wear heavy gloves to protect your hands.
- Carry out the adjustment with the tiller on the level ground and the engine stopped.

Disconnect the spark plug cap to prevent an accidental start-up.

1. Set the front wheel "For transportation" (see page 23).
2. Remove or install the outer rotary. Refer to page 48 for removal, page 50 for installation.
3. Set the front wheel at a condition other than "For transportation", and ground the rotary (see page 23).
4. Alter the rear wheel tread to adjust to the tilling width (see page 25).

Rear wheel tread adjustment

Rear wheel position can be changed to adjust the rear wheel tread in accordance with the tilling width.

1. Set the tiller on a firm level ground and hold it securely by placing a suitable block under the transmission case and raising the rear wheels off the ground.
2. Remove the retaining pin and wheel pin, and remove the rear wheels.
3. Reverse and slide the rear wheels onto the wheel shaft.
4. Insert the wheel pin by aligning the pin holes and install the retaining pin. Be sure to install the right and left rear wheels in the symmetrical positions.

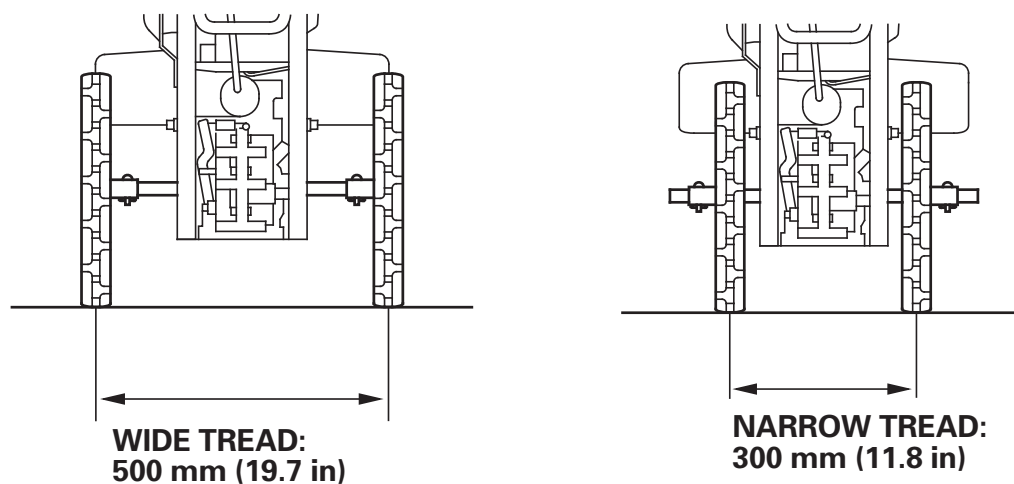
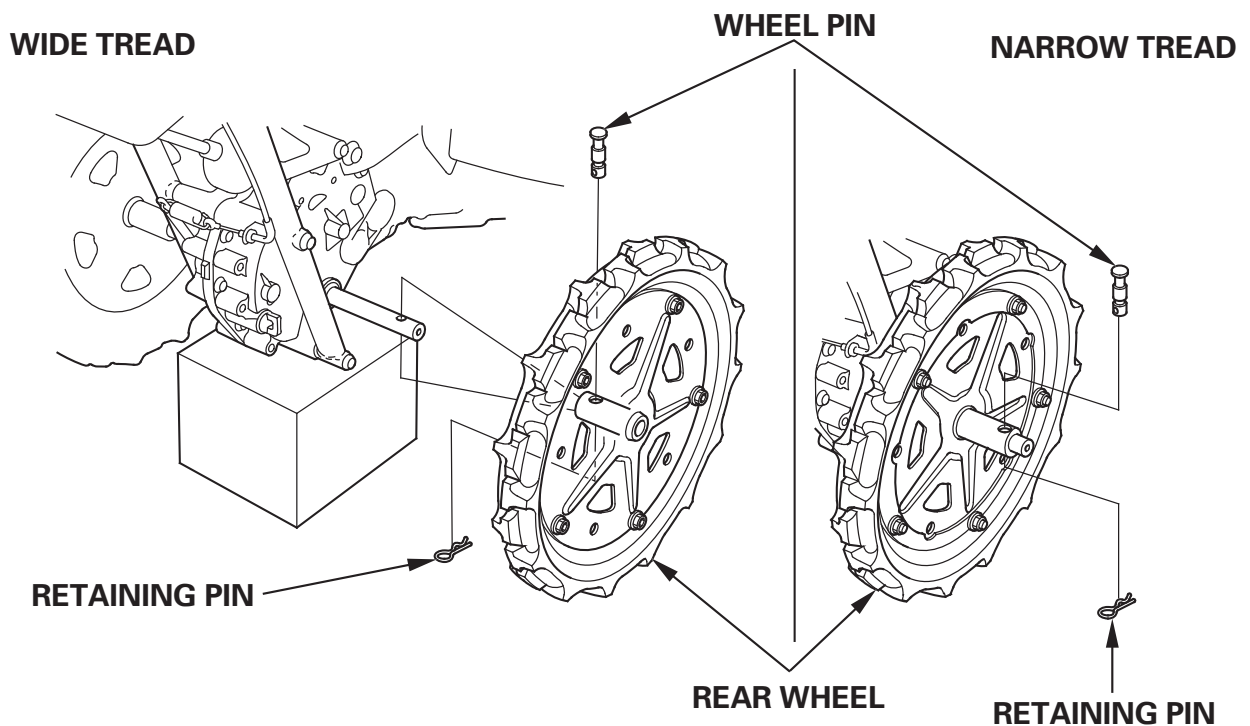

Handlebar position adjustment

Handlebar height can be set in either the HIGH or LOW position in accordance with the work or the height of the operator.

1. Place the tiller on a level surface with the rear wheels and tines on the ground and secure it not to move.
2. Remove the nut and handlebar height adjusting bolt.
3. Move the handlebar to the position you want. Install the bolt by aligning the bolt holes and tighten the nut securely.

Handlebar height:

- ① 950 mm (37.4 in)
- ② 835 mm (32.9 in)

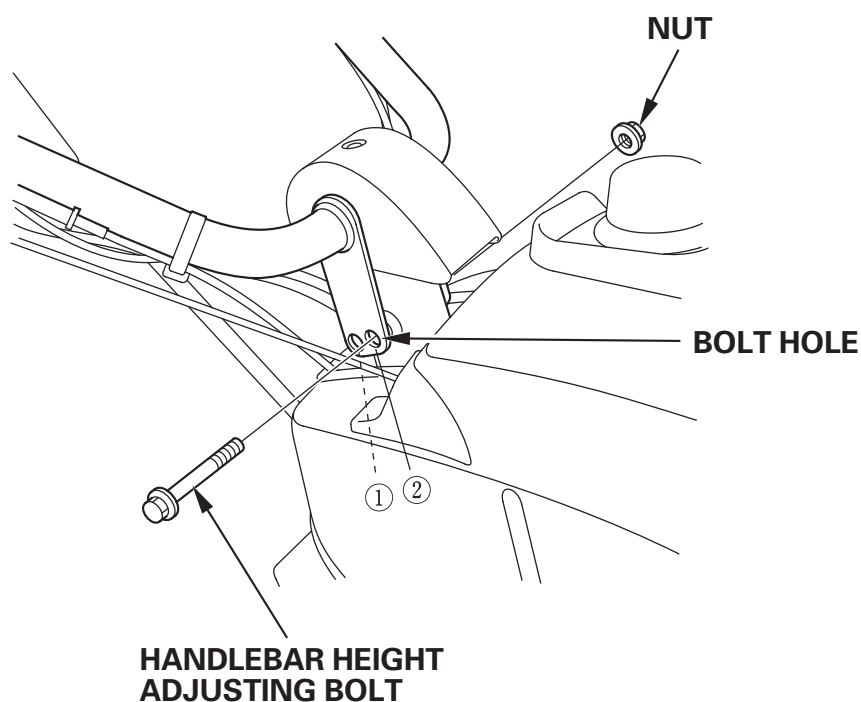
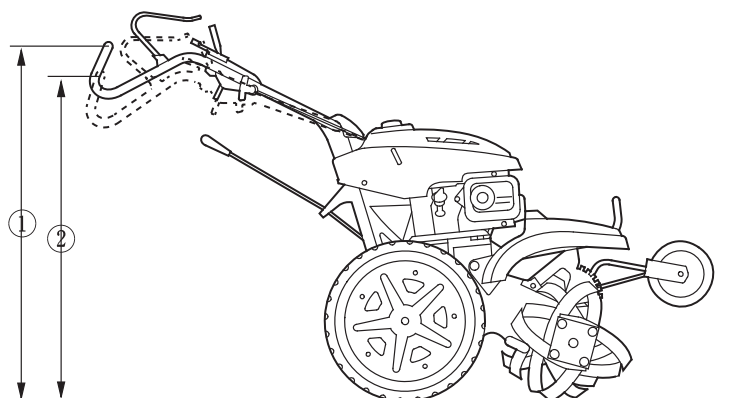

Gear selection

CAUTION:

Return the throttle lever to the low speed position and disengage the clutch before moving the gearshift lever. Avoid using excessive force on the gearshift lever.

Select a gear position in accordance with the contents of the Gear Selection Table (page 28).

- Always operate the gearshift lever after the main clutch has been disengaged.
- If the gearshift lever is difficult to operate, squeeze the main clutch once and then disengage the main clutch and operate the gearshift lever again.
- In reverse operation, be especially careful of your feet and observe the following precautions:
 - Make sure there are no people or obstacles behind you.
 - Lower the engine speed.
 - Hold the handlebar with both hands and support it firmly.
 - Gently engage the clutch and make sure that it can be disengaged at any time.

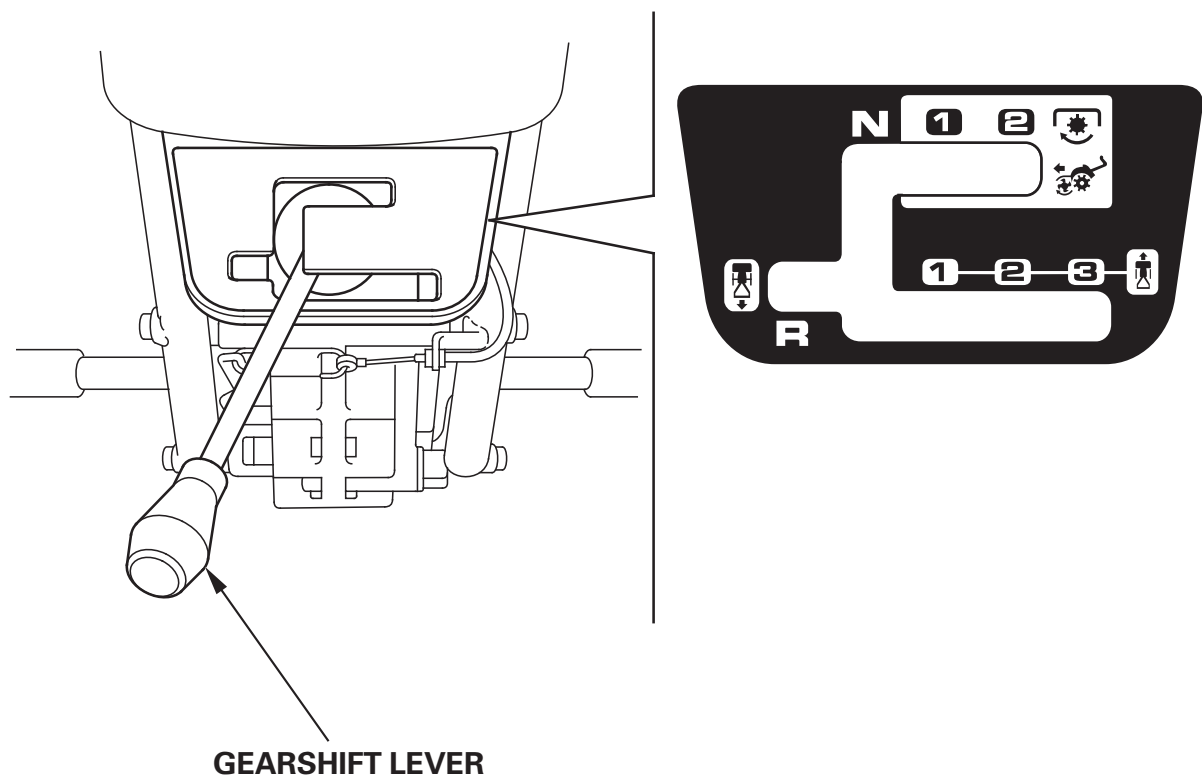

Gear Selection Table (When engine speed is 3,000 rpm)

Gear position	*Tiller speed	Rotary speed	Suitable work
1	0.18 m/s (0.59 ft/s)	—	Moving tiller, loading tiller onto a truck, taking tiller on or off field
2	0.31 m/s (1.02 ft/s)	—	Moving tiller, loading tiller onto a truck, taking tiller on or off field
3	1.00 m/s (3.28 ft/s)	—	Moving tiller
R	0.33 m/s (0.83 ft/s)	—	Moving tiller, unloading tiller from track, taking tiller on or off field
Tine/wheel engage 1	0.18 m/s (0.59 ft/s)	141 rpm	Tilling, ground breaking, weeding
Tine/wheel engage 2	0.31 m/s (1.02 ft/s)	141 rpm	Tilling, ground breaking, weeding

* Tiller speed applies when standard tires are used.

Handling tips

- Adjust the handlebar height to a comfortable position (waist height for normal tilling).
- If the machine will not move forward, release the main clutch lever and press down on the handlebar to raise the rotary little and pull the tiller backward slightly, then raise the handlebar and pull the main clutch lever to work.
- Stop the tines before crossing gravel drives, walks, or roads. Stay alert for hidden hazards or traffic.
- Stop the engine immediately if the tiller vibrates abnormally. Check the tiller for damage or loose parts, and repair or replace them before using the tiller again.
- Turning:
Release the main clutch lever and lower the engine speed.
Move the differential lock lever to the UNLOCK position.
Set the gearshift lever to the 1 position.
Press the handlebar to raise the rotary little, and pull the main clutch lever and turn the tiller.
After turning, release the main clutch lever and move the gearshift lever to the Tine/wheel engaged position to work.

Main clutch operation

The clutch engages and disengages the power from the engine to the transmission.

CAUTION:

When operating the tiller, always walk behind and in the center of the tiller and hold the handlebar with both hands. If the tiller becomes imbalanced, an unforeseen accident may occur.

When the main clutch lever is squeezed, the clutch is engaged and power is transmitted to the transmission.

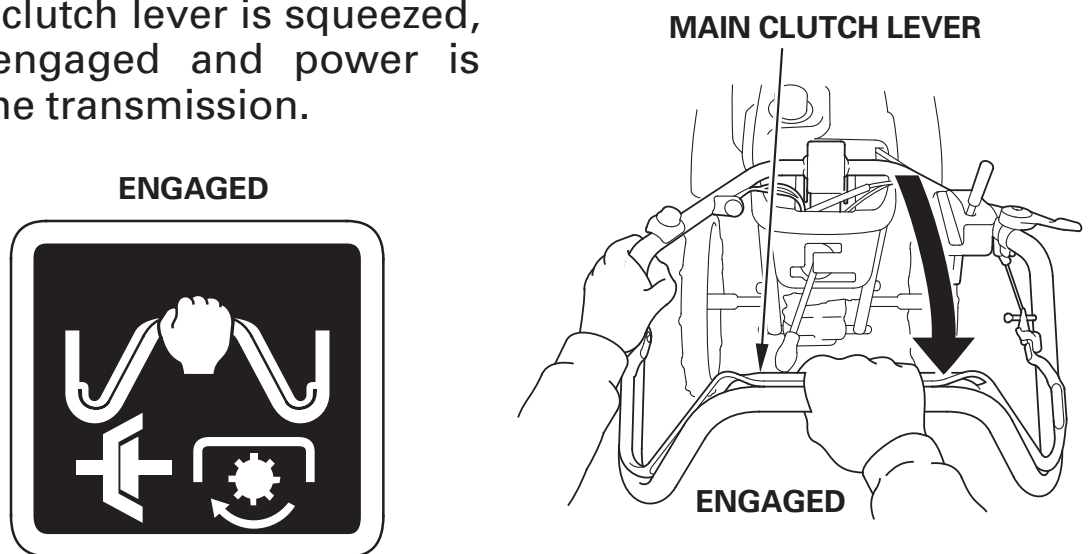

Hold the clutch lever properly in accordance with the work and your height.

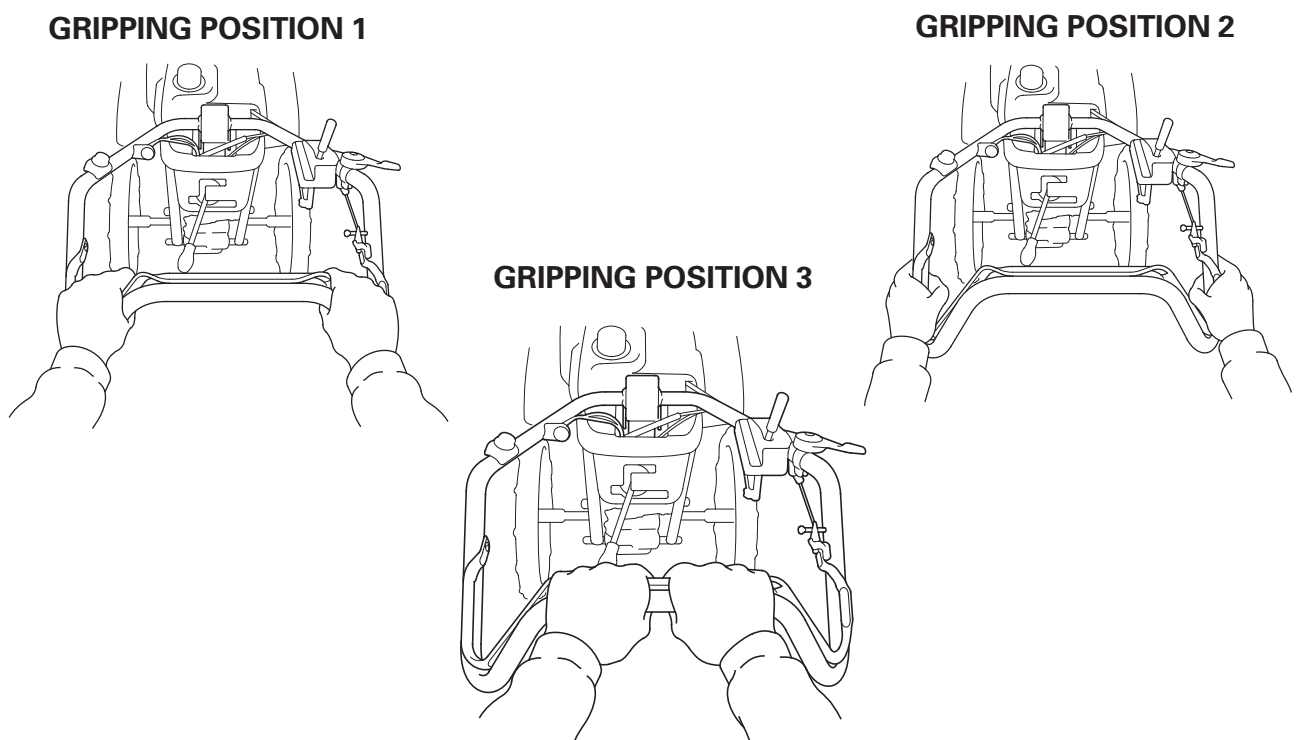

CAUTION:
Squeeze the main clutch lever with care not to pinch your hand between the handlebar and main clutch lever.

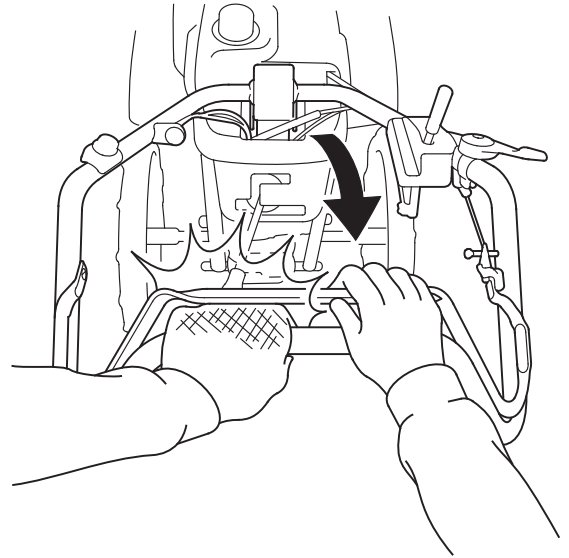

When the main clutch lever is released, the clutch is disengaged and power is not transmitted to the transmission.

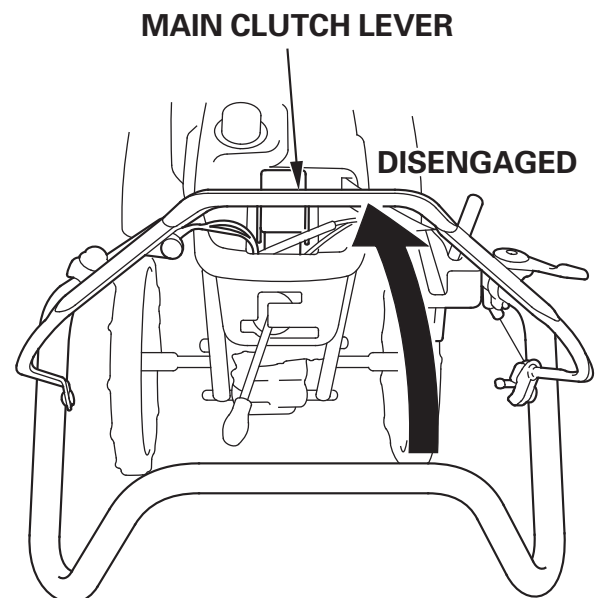

NOTE:

- Operate the main clutch lever smoothly.
- If the main clutch lever is operated erratically, the tiller may jump away or the engine may stop.

Differential lock operation

For normal operation set the differential lock lever in the UNLOCK position. This improves tiller's turning ability.

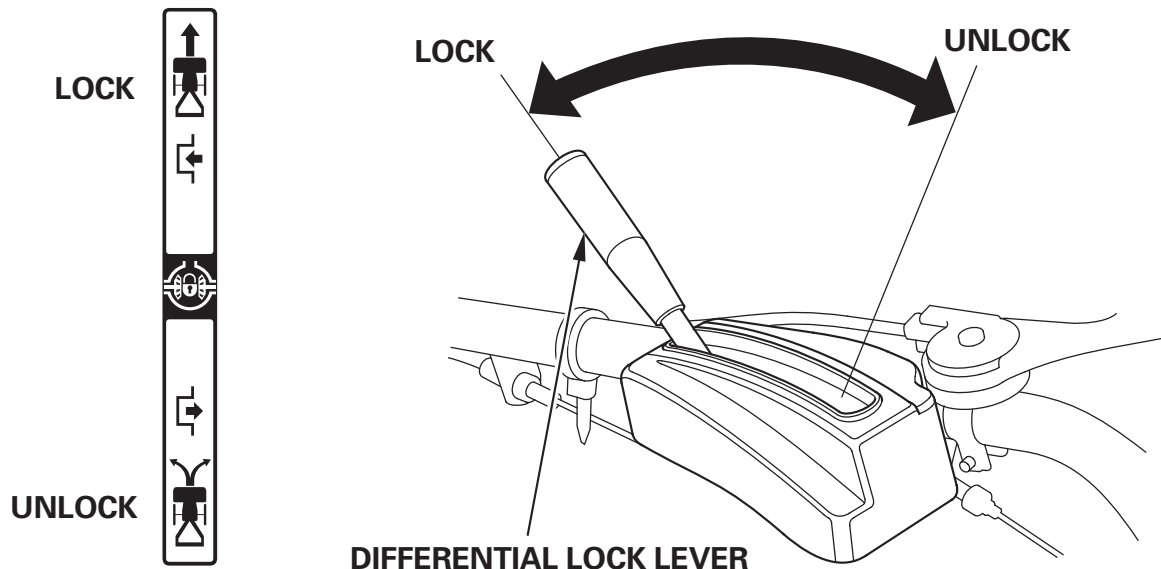

When the ground is soft and one wheel tends to slip or when only one side is to be tilled, set the differential lock in the LOCK position. This improves the tiller forward movement ability.

Move the differential lock lever after the main clutch has been disengaged and the tiller has stopped.

- When moving the tiller, set the differential lock lever in the UNLOCK position.
- If the differential lock lever is operated with the main clutch lever squeezed, the differential lock mechanism may be damaged. Operate the differential lock lever with the main clutch lever disengaged.
- When the tiller is running on a slope or uneven ground, set the differential lock lever in the LOCK position.

CAUTION:

- **Do not try to turn the tiller at high speed. The tiller turns quickly, which leads to unstable driving of the tiller and possibly causes injury to the operator and/or the bystanders.**
- **Do not try to turn the tiller on a slope. The tiller turns quickly to an unexpected direction, possibly causing personal injury and damage to the tiller as well as to the property.**

7. STOPPING THE ENGINE

- In an emergency:
Turn the engine switch to the OFF position.

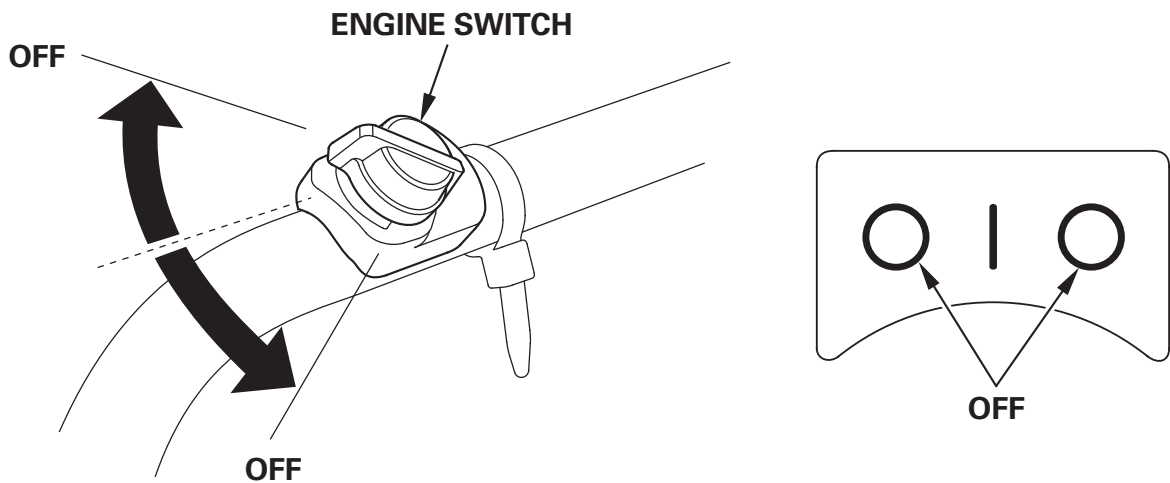

- In normal use:
1. Release the main clutch lever to the DISENGAGED position.

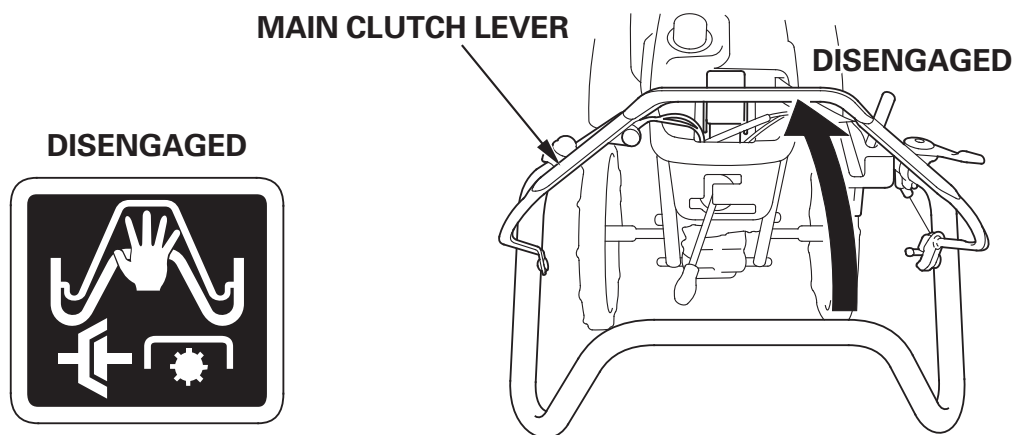

- 2. Move the throttle lever toward the slowest position and reduce the engine speed.

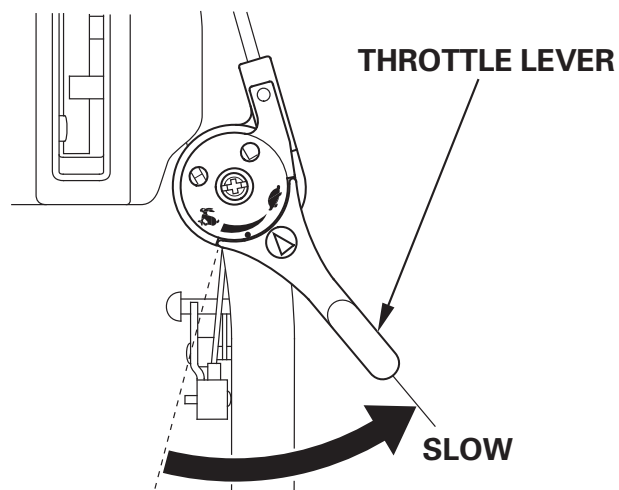

3. Set the gearshift lever in the NEUTRAL position.

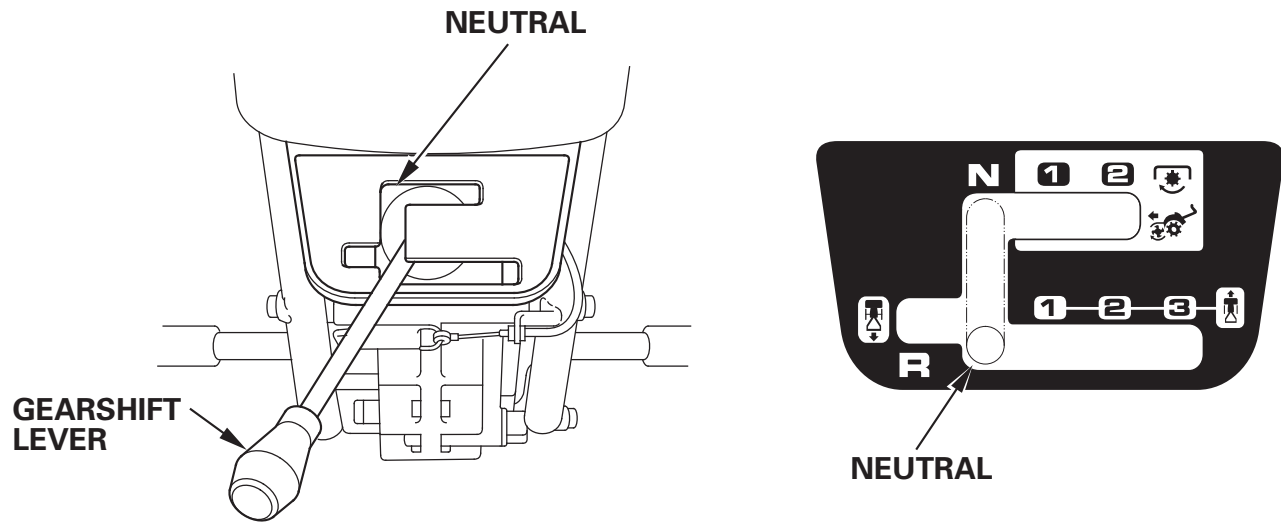

4. Turn the engine switch to the OFF position.

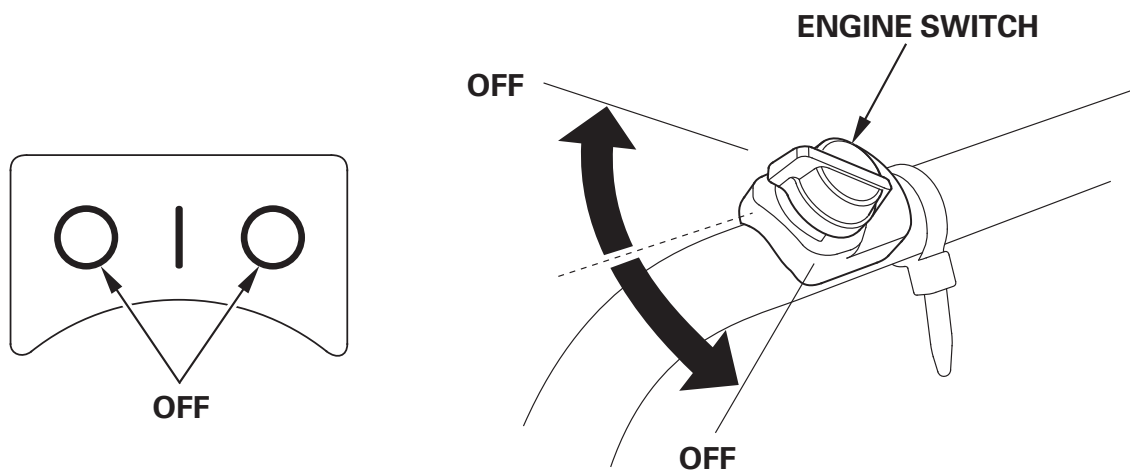

5. Turn the fuel valve to the OFF position.

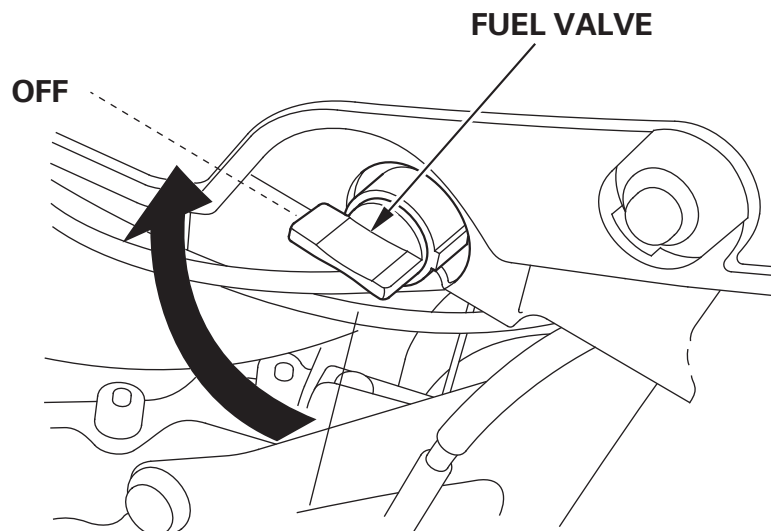

8. MAINTENANCE

The purpose of the maintenance schedule is to keep the tiller in the best operating condition. Inspect or service as scheduled in the table on page 35 .

▲WARNING

- **Shut off the engine before performing any maintenance. Exhaust contains poisonous carbon monoxide gas; Exposures cause loss of consciousness and may lead to death. If the engine must be run, make sure the area is well ventilated.**
- **To prevent an accidental start-up, disconnect the spark plug cap.**

CAUTION:

Use only genuine Honda parts or their equivalent for maintenance or repair. Replacement parts which are not of equivalent quality may damage the tiller.

Maintenance schedule

REGULAR SERVICE PERIOD (2)		Before season	Each use	First month or 20 hrs.	Every 3 months or 50 hrs.	Every 6 months or 100 hrs.	Every year or 250 hrs.
ITEM							
Engine oil	Check level		○				
	Change	○		○		○ (4)	
Air cleaner	Check		○				
	Clean				○ (1)		
	Replace						○
Tiller outside	Check		○				
Control lever function	Check		○				
Bolts and Nuts tightens	Check-tighten		○				
Wirings & cables	Check		○				
Engine operation	Check		○				
Transmission oil	Check level	○					
Clutch oil	Check level	○					
Clutch shoe	Check						○ (3)
Spark plug	Check-adjust					○	
	Replace						○
Throttle cable	Check-adjust						○
Main clutch cable	Check-adjust			○		○	
Differential lock cable	Check-adjust			○		○	
Valve clearance	Check-adjust						○ (3)
Combustion chamber	Clean	After every 250 hrs. (3) (5)					
Fuel tank and filter	Clean	○ (3)					○ (3)
Fuel tube	Check	Every 2 years (Replace if necessary) (3)					

- (1) Service every 10 operation hours or every day when used in dusty areas.
- (2) Perform at every indicated month or operating hour interval, whichever comes first.
- (3) Service of these items requires you to have the adequate tools and skill. Consult with your authorized Honda dealer for service.
- (4) Replace the engine oil every 100 operating hours when used under high load and high temperature.
- (5) Service at the indicated service interval.

Engine oil change

1. Remove the oil filler cap/dipstick and the oil drain plug to drain the engine oil.
2. Reinstall the oil drain plug and tighten it securely.
3. Refill with the recommended oil and check the oil level (see page 13).
4. Reinstall the oil filler/cap dipstick

Oil capacity: 0.55 ℓ (0.58 US qt , 0.48 Imp qt)

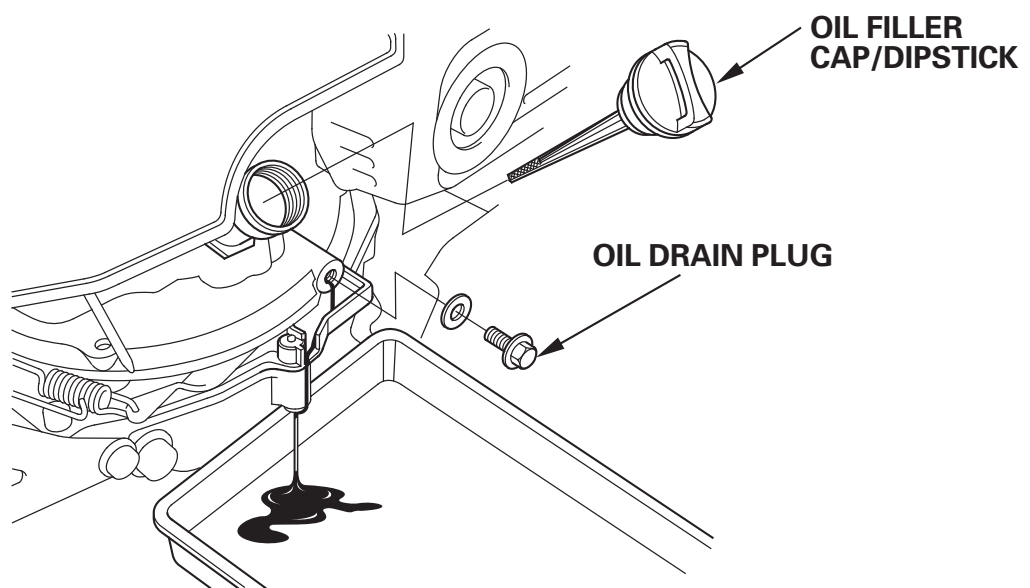

Wash your hands with soap and water after handling used oil.

NOTE:

Please dispose of used motor oil in a manner that is compatible with the environment. We suggest you take it in a sealed container to your local service station for reclamation. Do not throw it in the trash or pour it on the ground.

Air cleaner service

A dirty air cleaner will restrict air flow to the carburetor. To prevent carburetor malfunction, service the air cleaner regularly. Service more frequently when operating the engine in extremely dusty areas.

CAUTION:

Never run the engine without the air cleaner. Rapid engine wear will result.

1. Push the latch tabs and pull the air cleaner cover out of the air cleaner case, then disengage the lower hooks from the air cleaner case and remove the air cleaner cover.

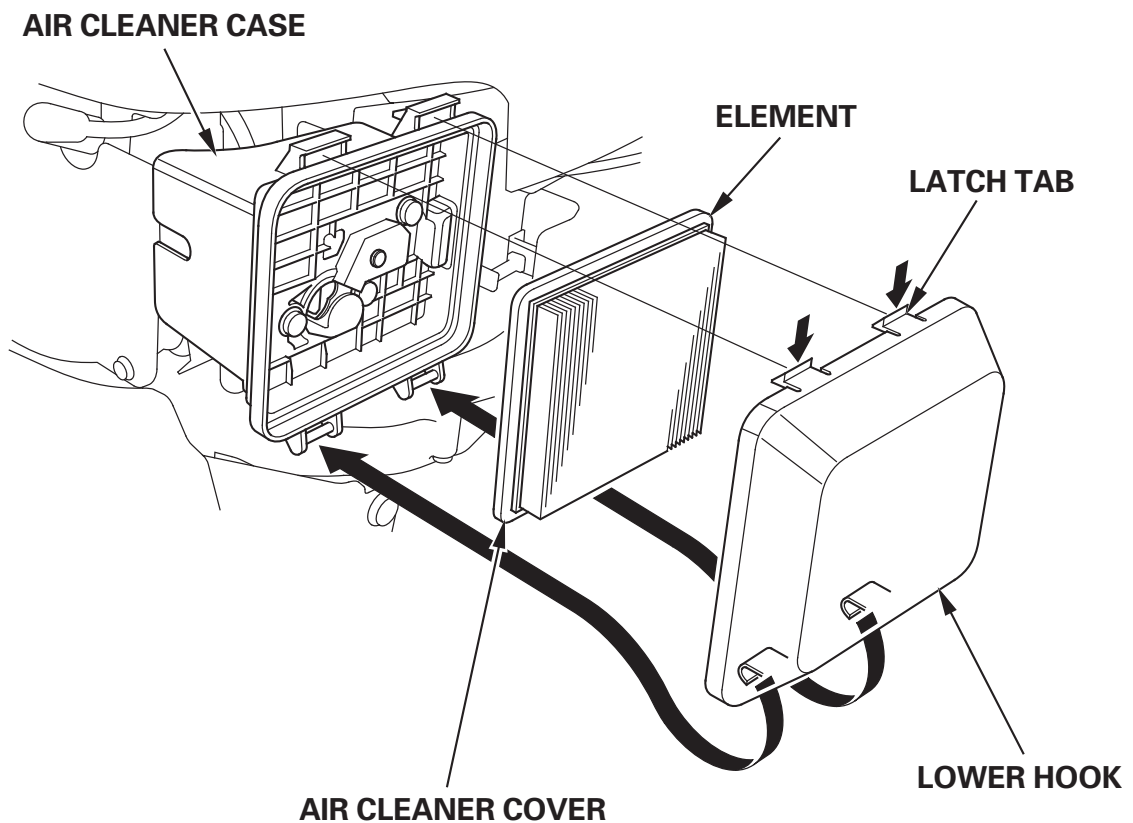

2. Remove the element. Carefully check the element for holes or tears and replace it if damaged.

-
3. Tap the element lightly several times on a hard surface to remove excess dirt, or blow compressed air through the filter from the inside out. Never try to brush the dirt off; brushing will force dirt into the fibers. Replace the element if it is excessively dirty.

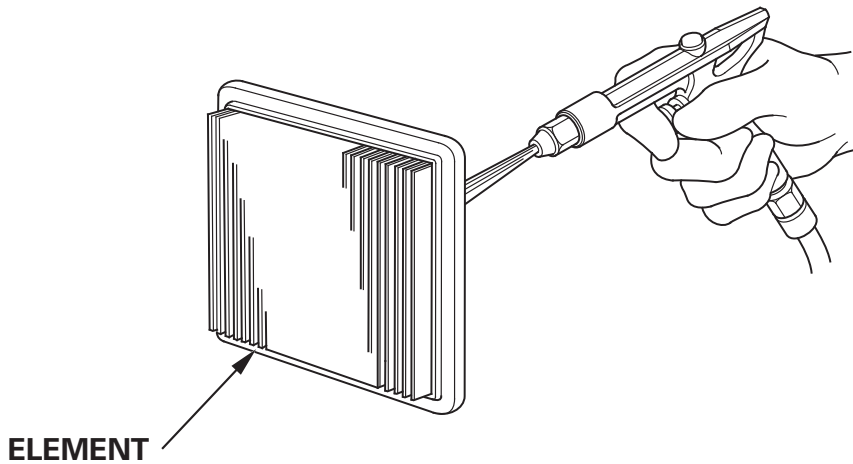

4. Install the element and the air cleaner cover.
To install the air cleaner cover, first set the lower hooks to the mounting pins on the air cleaner case, then push the air cleaner cover to set the latch tabs into the groove of the air cleaner case.

Clutch oil inspection

1. Stop the engine and set the tiller on a firm level ground with the rear wheels and tines.
2. Place a 60 mm (2.4 in) thick block under the rear wheels as shown.
3. Remove the oil level check bolt and check that the oil is level with the lower edge of the oil level check hole.

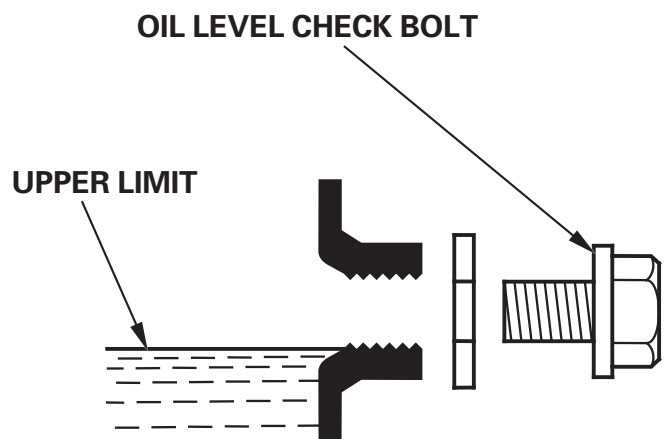
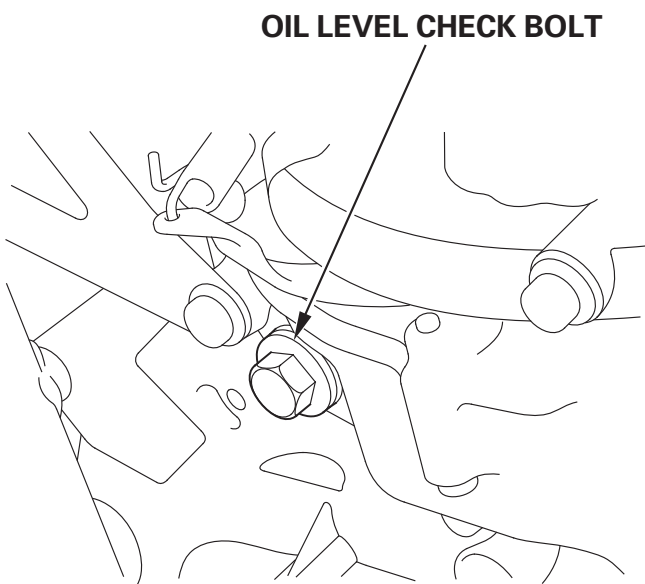
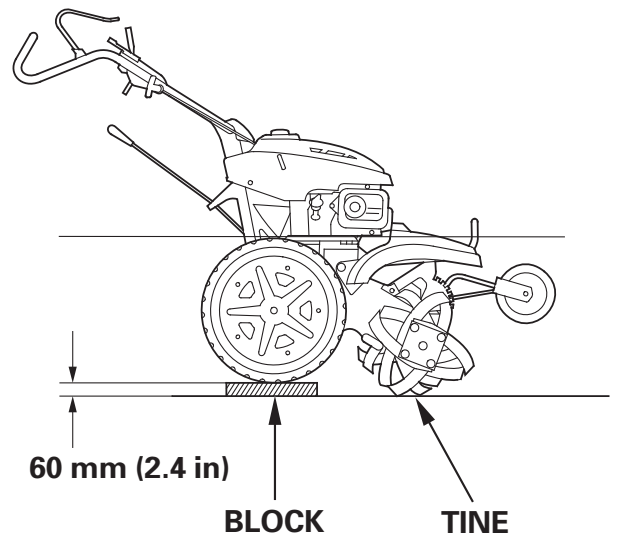

4. Add the recommended oil if the level is low.

Recommended oil:

Use SAE 0W-20 Honda 4-stroke oil or SAE 0W-20 4-stroke motor oil that meets the requirements for API service classification SL or equivalent. Always check the API service label on the oil container to be sure it includes the letters SL or equivalent.

5. Reinstall the check bolt and tighten it securely.

Transmission oil inspection

1. Stop the engine and set the tiller on a firm level ground with the rear wheels and tines as shown.
2. Remove the oil filler cap and check that the oil is level with the lower edge of the oil filler hole.

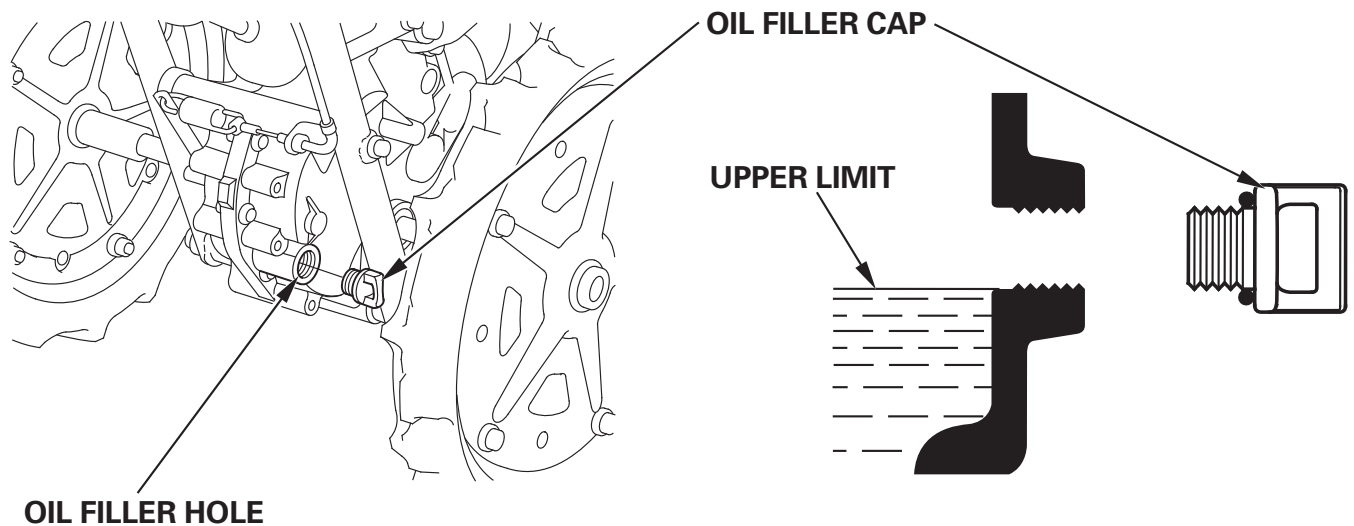
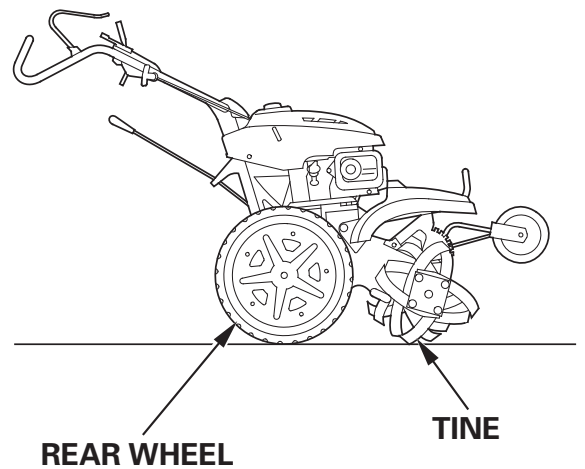

3. Add the recommended oil if the level is low.

Recommended oil:

Use 10W-30 4-stroke motor oil that meets or exceeds the requirements for API service classification SE or later (or equivalent). Always check the API service label on the oil container to be sure it includes the letters SE or later (or equivalent).

4. Reinstall the oil filler cap securely.

Spark plug service

Recommended spark plug: BPR6ES (NGK)

CAUTION:

Never use a spark plug with an improper heat range.

To ensure proper engine operation, the spark plug must be properly gapped and free of deposits.

1. Disconnect the spark plug cap.
2. Remove the spark plug with spark plug wrench.

⚠ WARNING

If the engine has been running, the muffler will be very hot. Be careful not to touch the muffler.

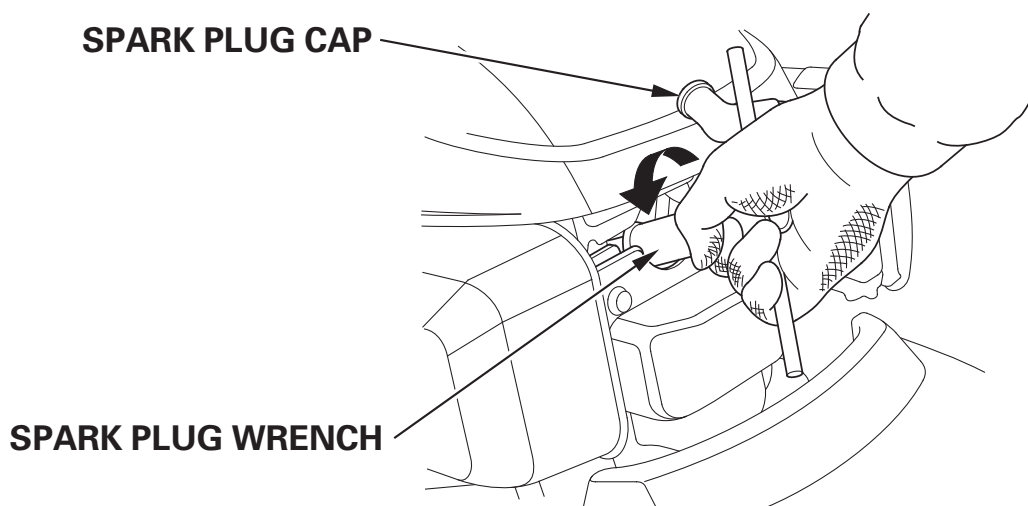

3. Visually inspect the spark plug. Discard it if the insulator is cracked or chipped. Clean the spark plug with a wire brush if it is to be reused.

4. Measure the plug gap with a feeler gauge.
The gap should be:
0.7 – 0.8 mm (0.028 – 0.031 in)

Correct as necessary by bending the side electrode.

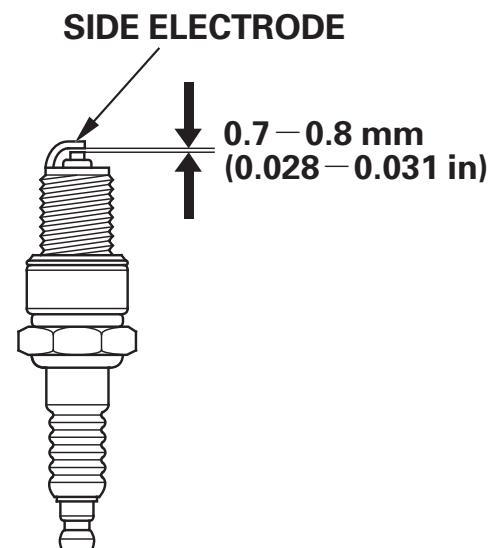

-
5. Check that the spark plug washer is in good condition and thread the spark plug in by hand to prevent cross-threading.
 6. After the spark plug is seated, tighten with a spark plug wrench to compress the washer.
When installing a new spark plug, tighten 1/2 turn after the spark plug seats to compress the washer.
When reinstalling the used spark plug, tighten 1/8-1/4 turn after the spark plug seats to compress the washer.

CAUTION:

The spark plug must be securely tightened. An improperly tightened plug can become very hot and possibly damage the engine.

7. After installing the spark plug, install the spark plug cap securely.

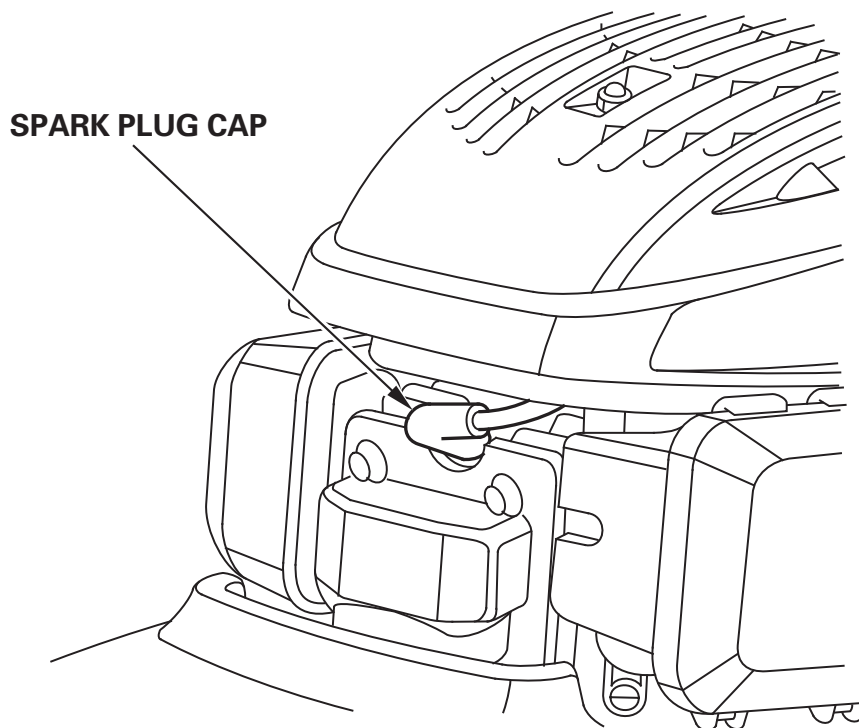

Throttle cable adjustment

1. Move the throttle lever to the slowest position.
2. Check the free play of the throttle lever at the end of the lever.
Free play should be:
10–15 mm (0.4–0.6 in)
3. If adjust is necessary, loosen the lock nut and turn the adjuster until the correct throttle lever free play is obtained.
4. After adjustment, tighten the lock nut securely.

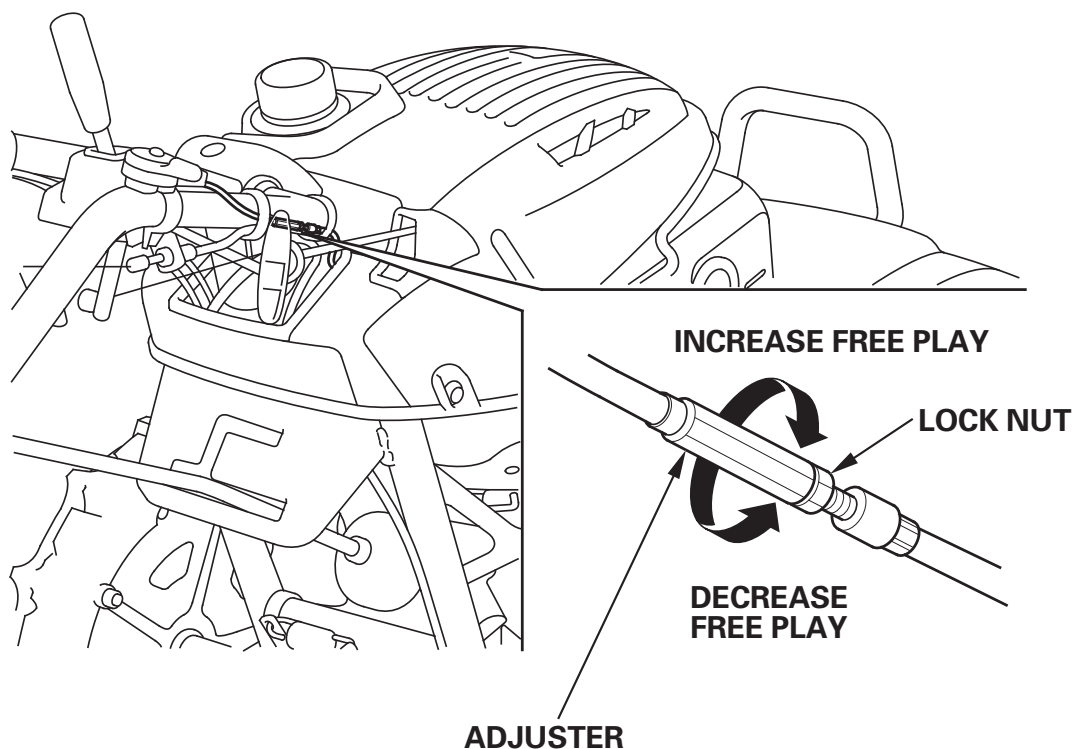
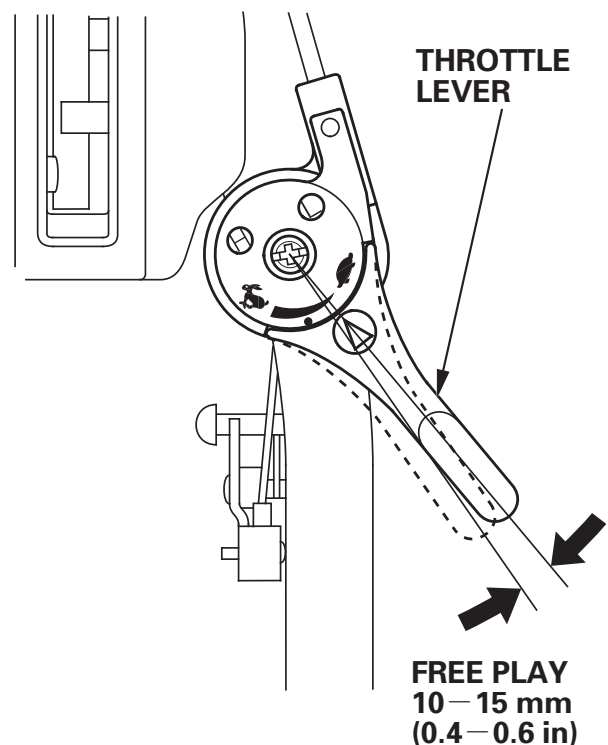

Main clutch cable adjustment

1. Pull the main clutch lever to the ENGAGED position, and check the extension value of the clutch spring at the end of the longer spring hook as shown.

Extension value should be:

2.5 – 3.5 mm (0.10 – 0.14 in)

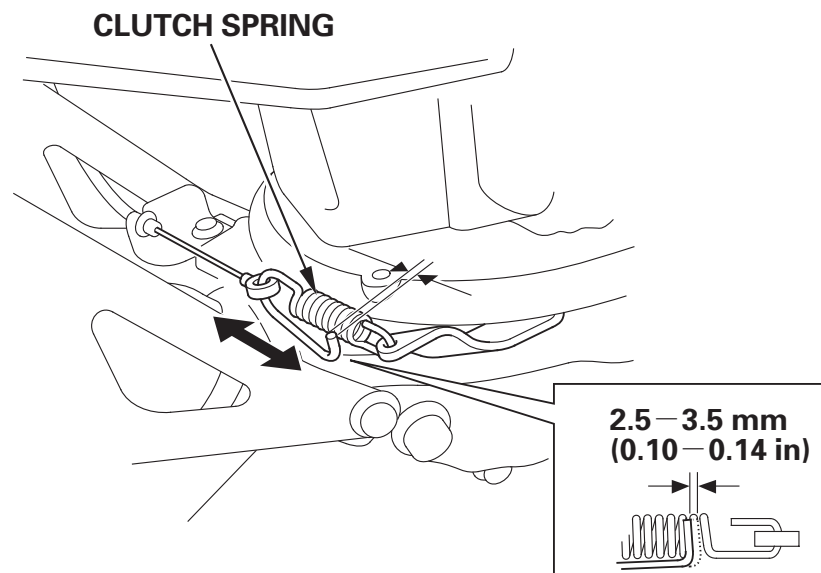

2. If adjustment is necessary, set the main clutch lever to the ENGAGED position.
3. Loosen the lock nut and turn the adjusting nut to obtain the correct extension value of the clutch spring.
4. After adjustment, tighten the lock nut securely.

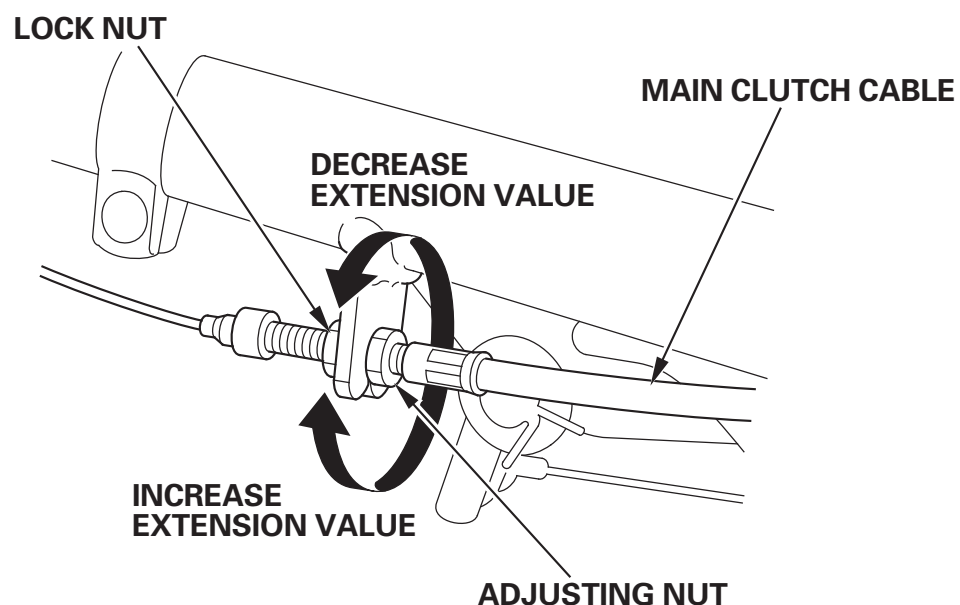

Differential lock cable adjustment

1. Set the differential lock lever in the UNLOCK position.
2. Check the differential lock lever free play at the end of the lever.
Differential lock lever free play should be:
1–5 mm (0.04–0.20 in)

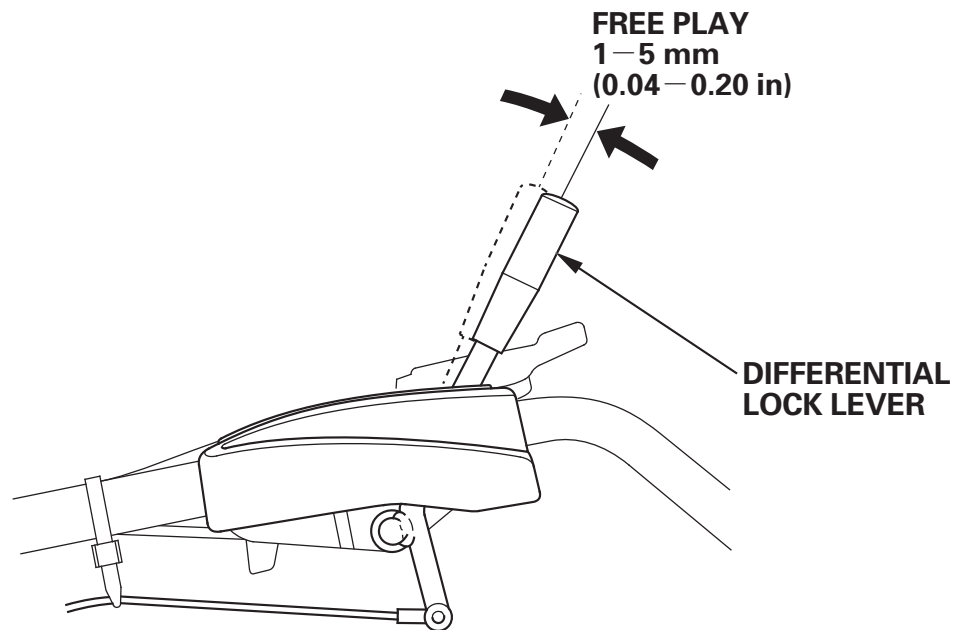

3. Adjustment is necessary, loosen the lock nut and turn the adjusting nut.
4. After adjustment, tighten the lock nut securely.

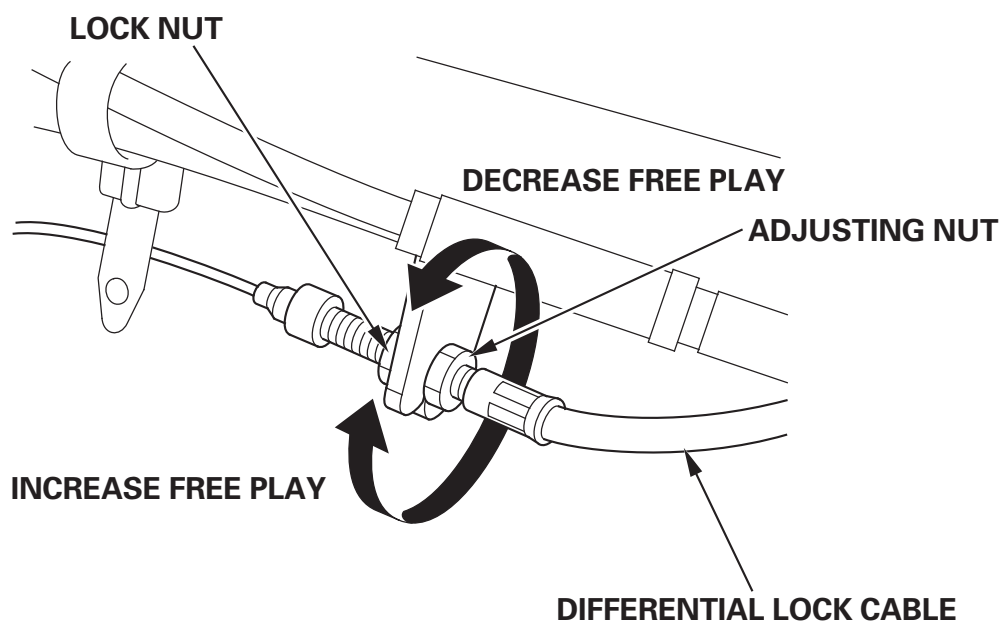

Rotary tines inspection and replacement

▲WARNING

- Wear heavy gloves to protect your hands.
- Carry out the check or replacement work with the tiller on the level spot and the engine stopped. Disconnect the spark plug cap to prevent an accidental start-up.
- Place a wooden block under the rotary tine to prevent rotary form dropping.
- The inside and outside tines rotate in opposite directions. Be careful of the movement of the tines when checking or replacing the rotary part. The rotary tines may turn in an unexpected direction, resulting injury.
- Incorrect arrangement of the tines or installing tines in wrong direction might case the tiller to move backward or move to an unexpected direction, resulting injury.

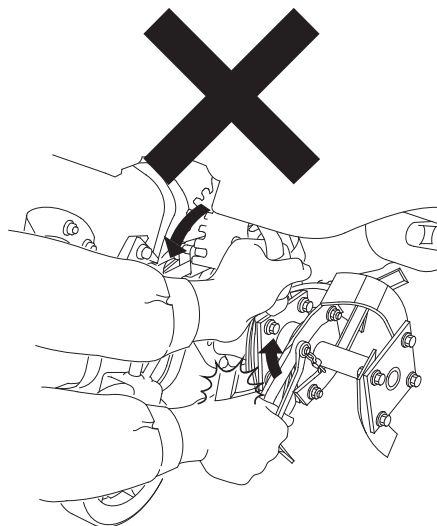

Before starting check or replacement work, set the front wheel to the lowermost position (for transporting see page 23) and place the tiller on a firm level ground and secure it not to move.

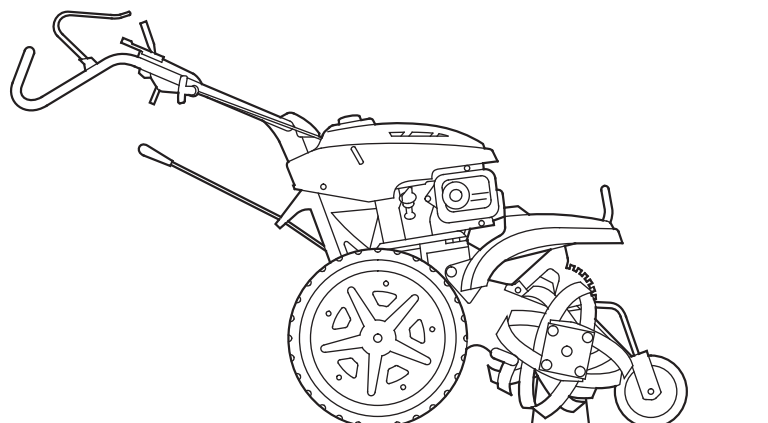

Inspection:

1. Check for damage, bent, or loose tines. If abnormality is found, tighten or replace the damaged part.
2. Check the rotary setting bolt for looseness, tighten if necessary.
3. Check the rotary pins and retaining pins for damage or missing, replace with new one if necessary (page 50).

NOTE:

Use genuine Honda parts or equivalent when replacing the rotary tines.

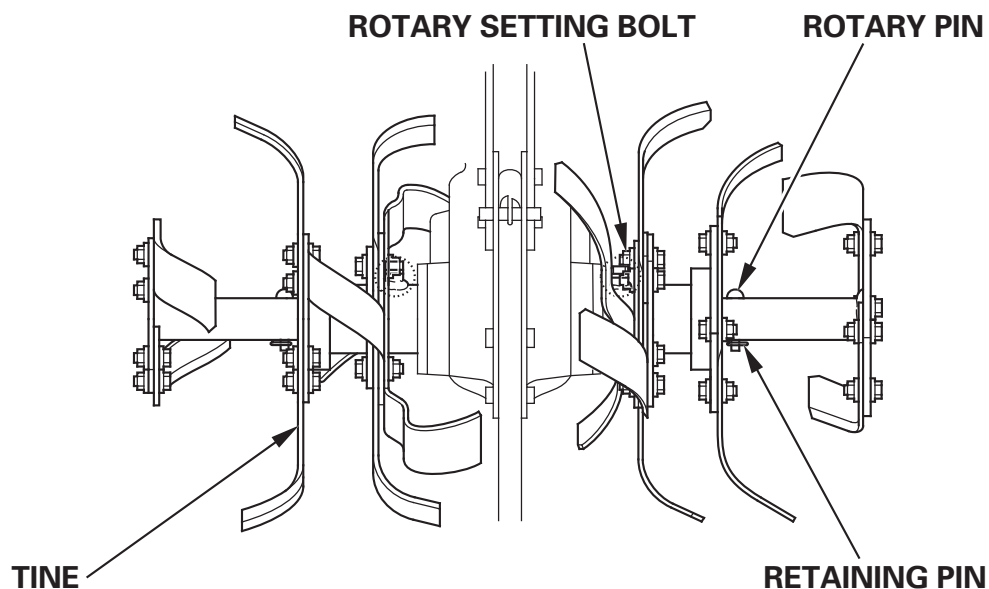

4. Check the tines for wear. Replace any tine if its width is less than 15 mm (0.6 in) in the range 80 mm (3.2 in) from the tip. Replace the tines earlier for efficient tilling.

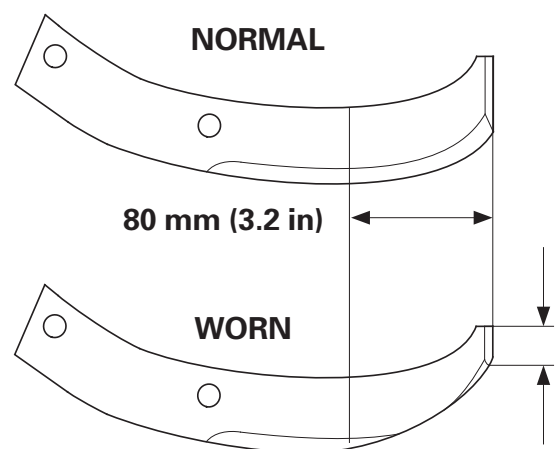

**15 mm (0.6 in) min.
Replace if out of
specification.**

Rotary removal:

1. Remove the retaining pin and rotary pin, then remove the outer rotary.
2. Remove the rotary setting bolt and spring washer, then remove the inner rotary and key. Store the key not to lose it.

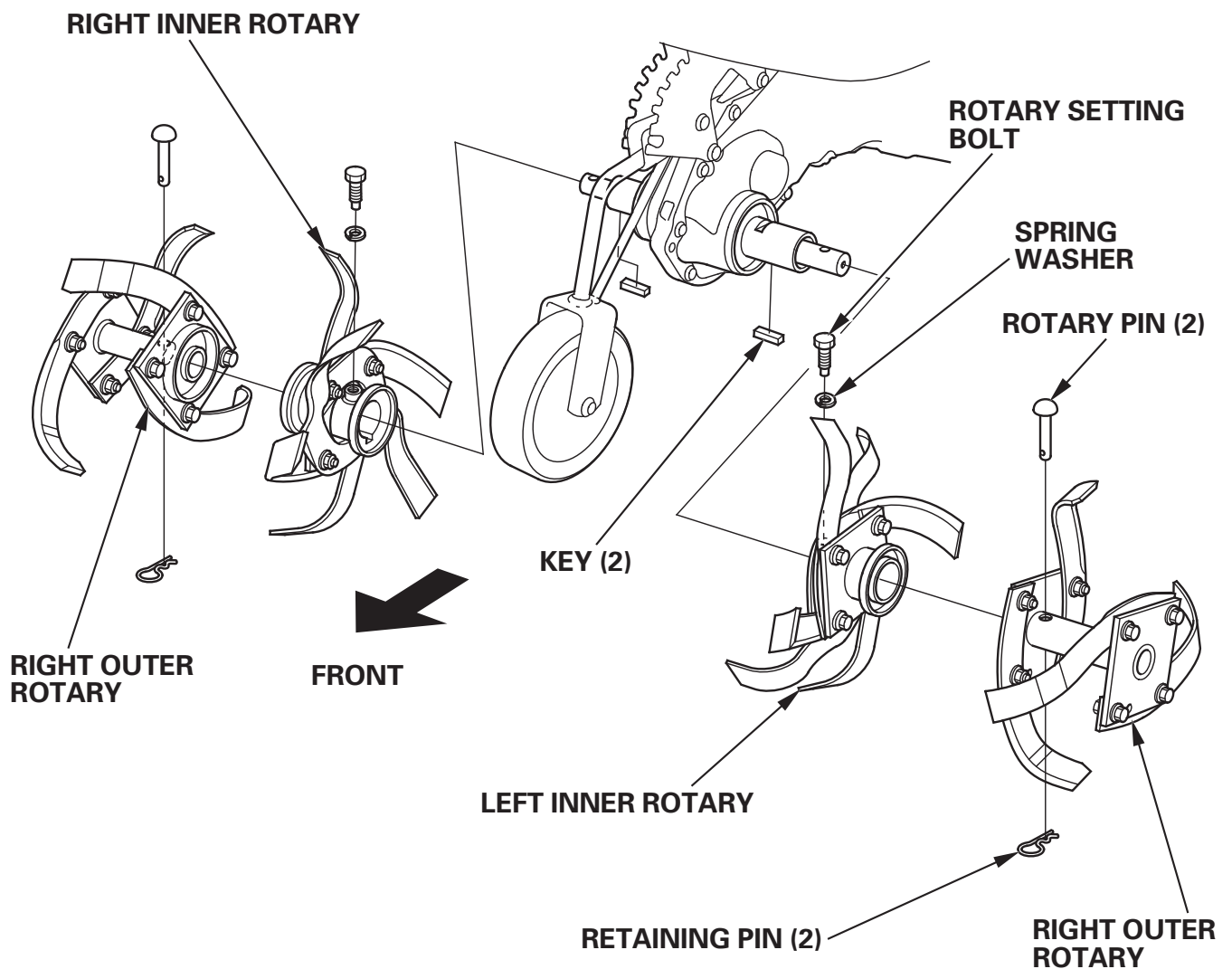

Rotary installation:

1. Apply grease to the key and set it on the key groove on the rotary shaft.
2. Install the inner rotary by aligning the key groove of the inner rotary with the key on the rotary shaft with "R" (right rotary) mark or "L" (left rotary) mark facing outside as shown.
3. Install the spring washer and rotary setting bolt, and tighten the rotary setting bolt securely.
Make sure that the rotary setting bolt is seated to the spring washer securely.

RIGHT INNER ROTARY
(Viewed from right side)

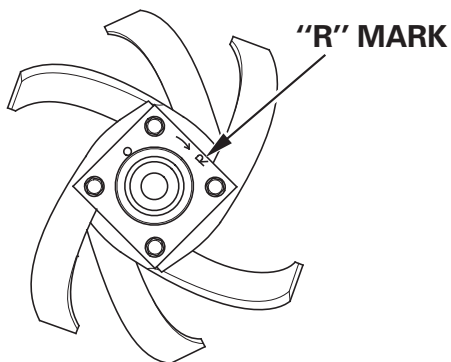

LEFT INNER ROTARY
(Viewed from left side)

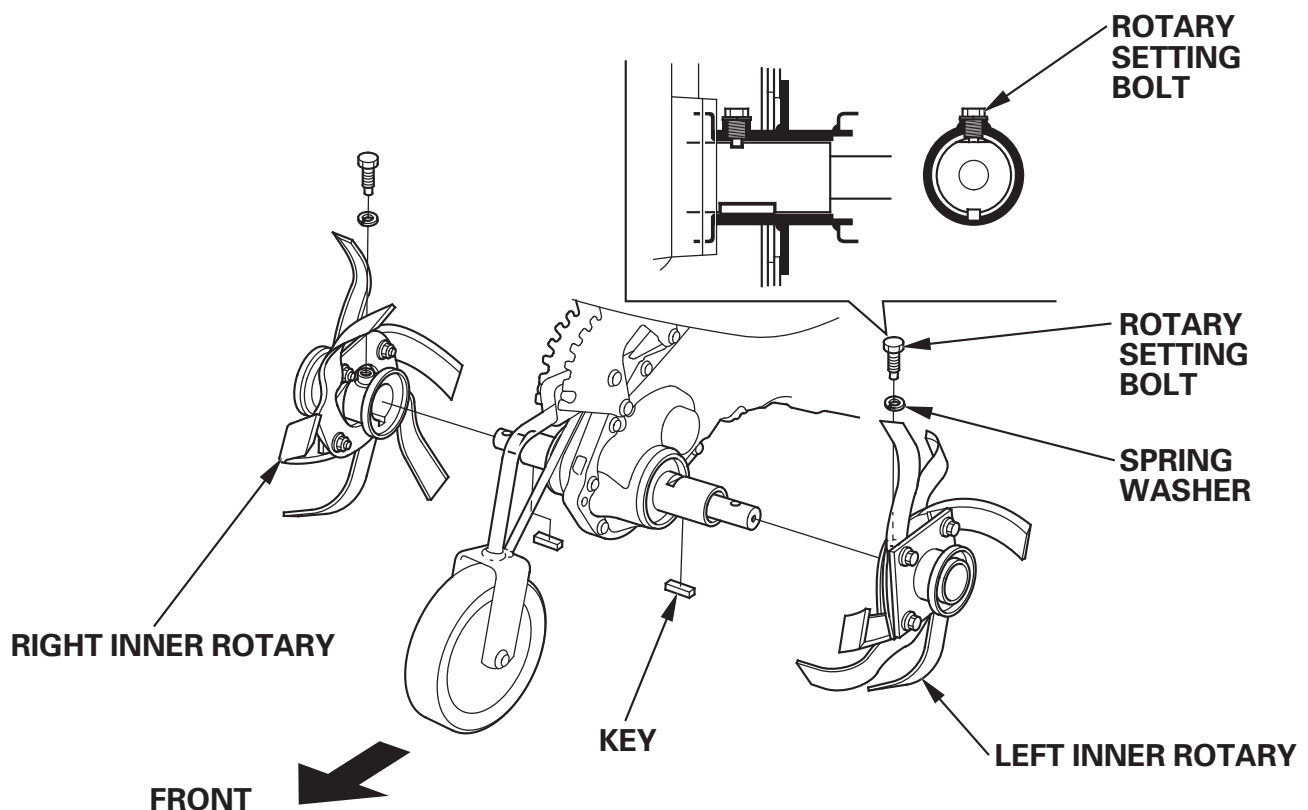
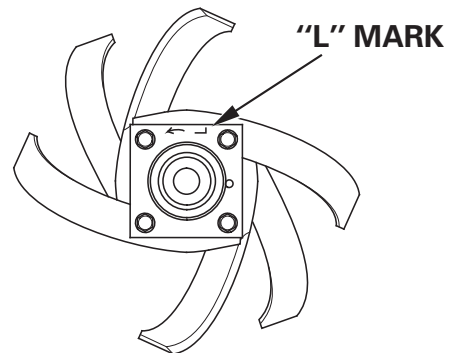

4. Install the outer rotary with the "R" (right rotary) mark or "L" (left rotary) mark facing outside as shown.
5. Align the pin holes of the outer rotary and rotary shaft, and install the rotary pin.
6. Install the retaining pin in direction shown.

RIGHT OUTER ROTARY
(Viewed from right side)

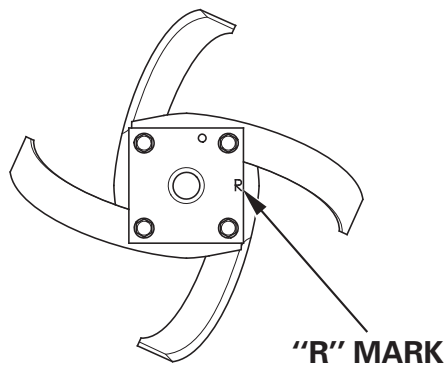

LEFT OUTER ROTARY
(Viewed from left side)

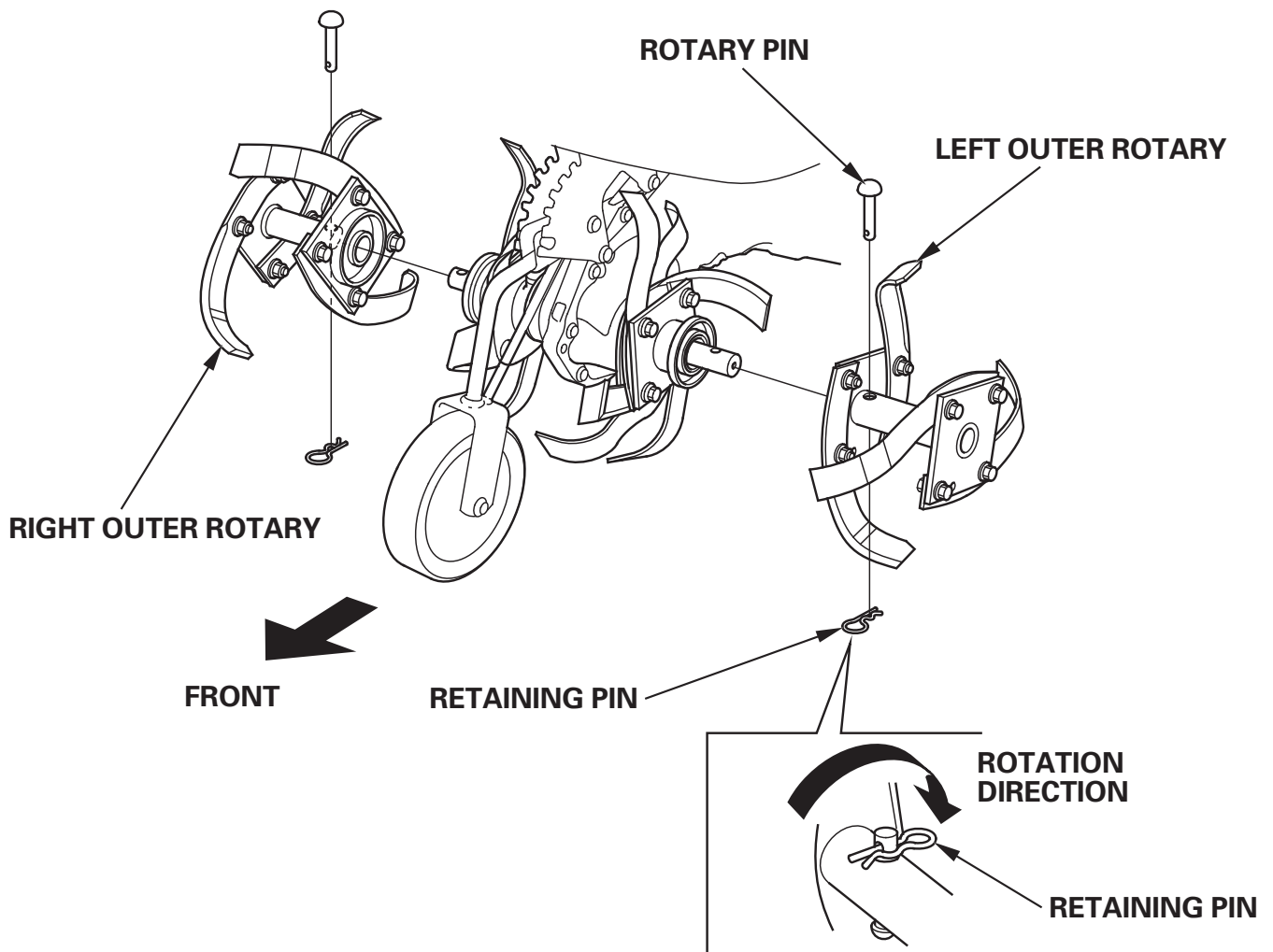
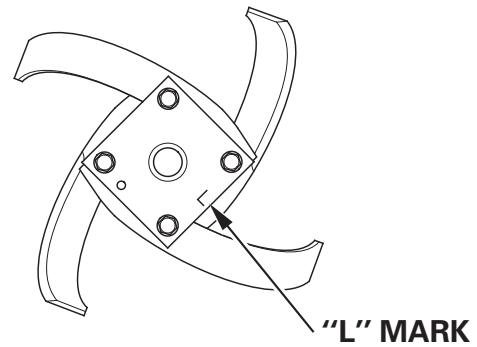

Tine installation:

Install the tines properly.

Incorrect arrangement of the tines or installing the tines in the wrong direction will cause vibration and hinder proper tilling.

- **Outer rotary tines:**

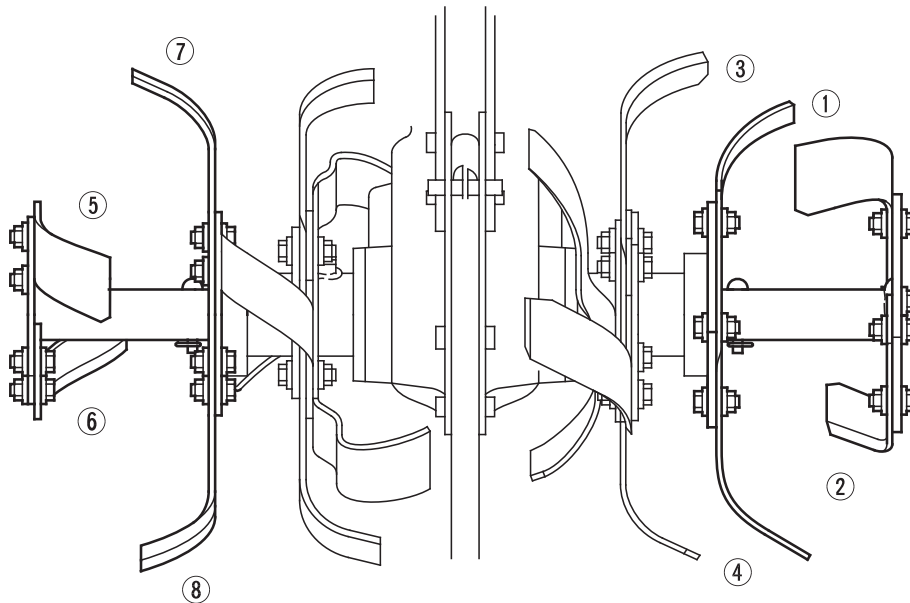

RIGHT OUTER ROTARY
(Viewed from right side)

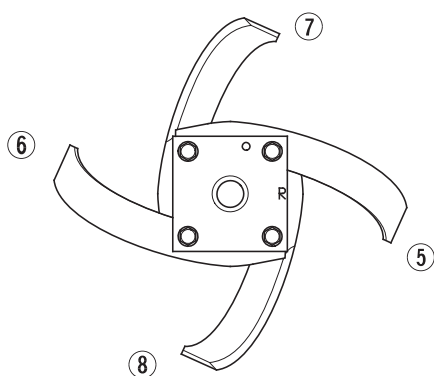

①, ②, ⑦ and ⑧: **TINE A**



LEFT OUTER ROTARY
(Viewed from left side)

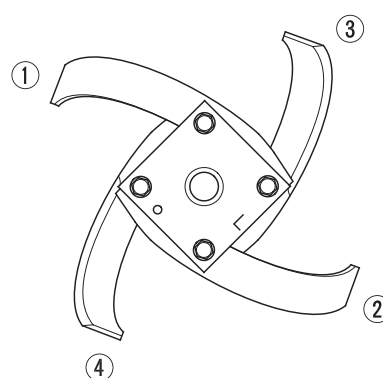

③, ④, ⑤ and ⑥: **TINE B**

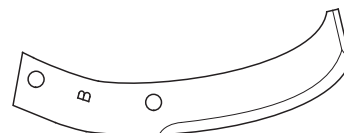

• Inner rotary tines

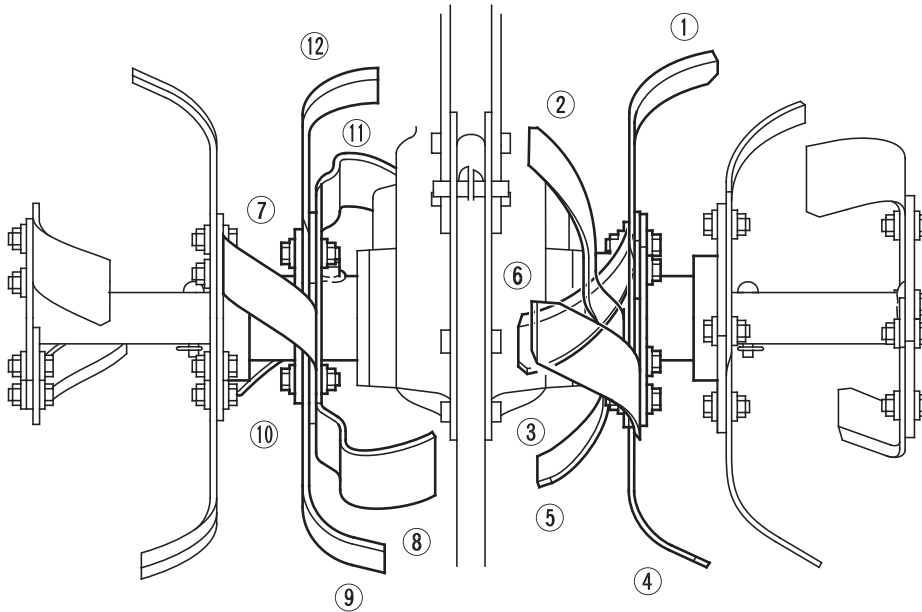

RIGHT INNER ROTARY
(Viewed from right side)

LEFT INNER ROTARY
(Viewed from left side)

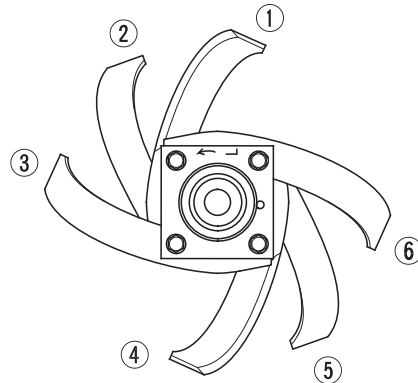
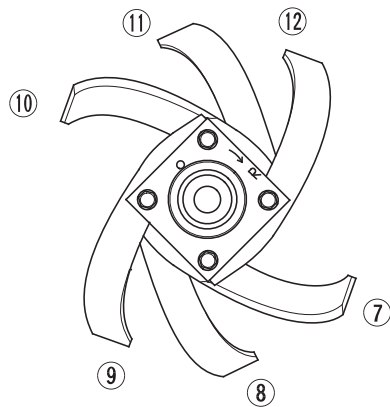

①, ④, ⑨ and ⑫: **TINE A**

③, ⑥, ⑦ and ⑩: **TINE B**

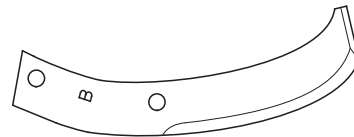
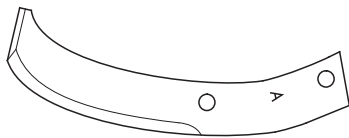

⑧ and ⑪: **TINE C**

② and ⑤: **TINE D**

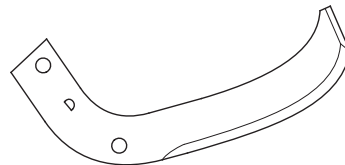
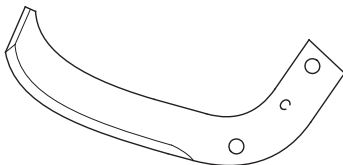

9. CLEANING AFTER USE

CAUTION:

- If the engine has been running, allow it cool for at least 30 minutes before cleaning.
- Wear heavy gloves to protect your hands while cleaning around the rotary tines.
- Carry out the cleaning with the tiller on the level spot.

1. Remove the mud, grass tips, dirt and other foreign matter from the tiller body and rotary tines.
2. Remove the mud and dirt around the air cleaner.
3. Wash the tiller, including the area around the rotary tines.
4. Wash the engine by hand, be careful to prevent water entering the air cleaner.

NOTE:

If using a garden hose or pressure washing equipment to clean the tiller, be careful to avoid getting water into controls and cables, or anywhere near the air cleaner and muffler opening.

5. After washing the tiller, wipe dry all accessible surface.

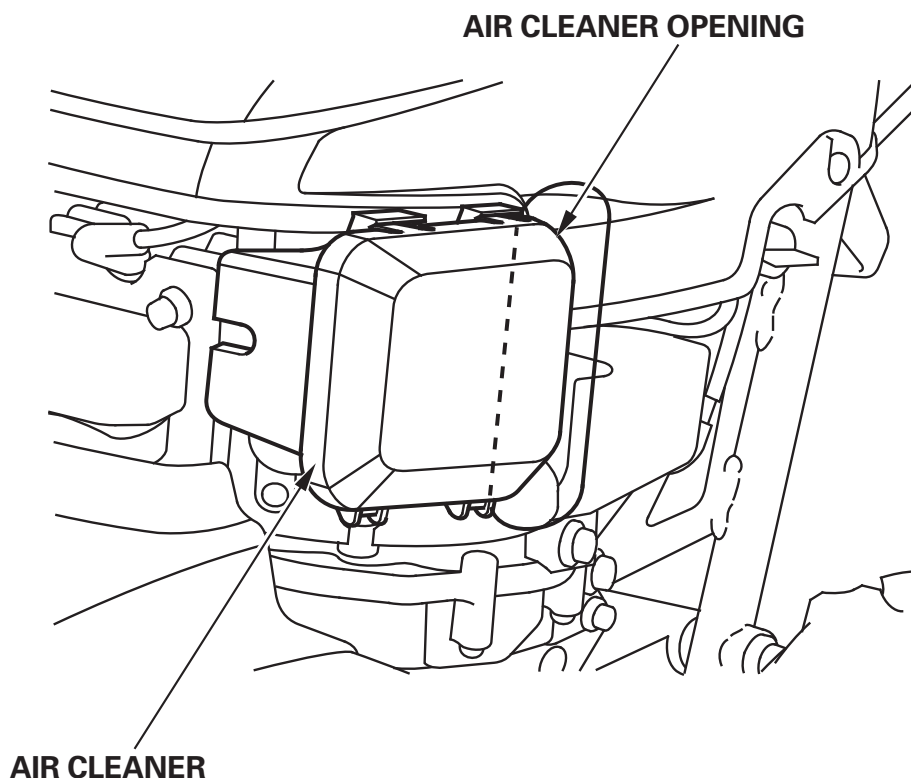

10. TRANSPORTING/STORAGE

Transporting

⚠ WARNING

Gasoline is flammable and explosive under certain condition. Do not smoke or allow flames or sparks in the area.

CAUTION:

If the tiller has been used, allow it cool for at least 15 minutes before loading it on the transport vehicle. A hot engine and exhaust system can burn you and can ignite some material.

- Take care not to drop or strike the tiller when transporting.
- Use a vehicle (e.g. truck, etc.) that satisfies the size, weight and other requirements of the tiller to transport.

Loading:

1. Raise the front wheel to the uppermost position (page 23).
2. Load the tiller on the transport vehicle and keep it level on the bed.

⚠ WARNING

Use a loading board whenever you load and unload the tiller onto/from the transport vehicle. Walk slowly on the loading board, or you can fall down from the loading board.

- Park the transport vehicle (e.g. truck, etc.) on a firm level surface and load/unload the tiller by using a loading board. Take care not to fall down from the loading board.
- Use a strong loading board that can support the weight of the tiller and attachment and long enough so that the tilt angle of the tiller can be 15° or less. Note that the loading board must be equipped with the non-slip and the hooks for secure attachment to the vehicle, and it must be wider than the tread of the tiller. (Guideline: Length of the loading board should be 4 times or more as long as the height of the bed of the vehicle.)

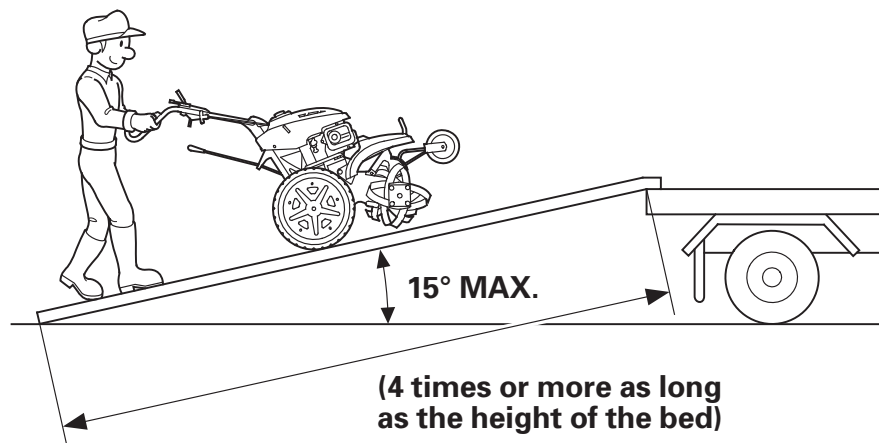

-
- Install the loading board straight and securely on the transport vehicle (e.g. truck, etc.).
 - Set the loading board parallel to the bed of the transport vehicle. Stand in the center of the loading board width and be sure that the right and left rear wheels of the tiller are parallel to the loading board.
 - Do not release the clutch lever during loading/unloading. The tiller can make abnormal movement when the clutch is released during loading/unloading.
 - Move the gearshift lever to the “TRANSPORT 1” position and check that the rotary is not turning before loading/unloading the tiller.
 - Set the differential lock lever in the “LOCK” position.
 - Set the gearshift lever in the “FORWARD” position for loading, and set the lever in the “REVERSE” position for unloading.
 - Start the engine and let it idle for 2 to 3 minutes before loading.

3. Secure the tiller to the bed by attaching rope to the handlebar and front guard pipe as shown.

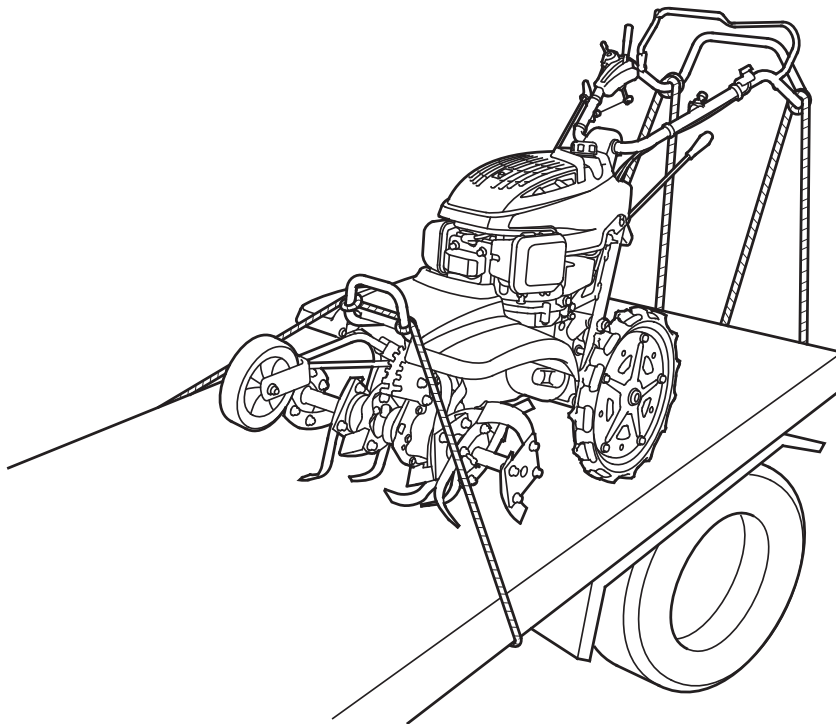

4. To prevent fuel spillage, drain the fuel from the carburetor (see page 56), make sure that the fuel valve is in the OFF position, and keep tiller level.

Storage

Before storing the unit for an extended period:

- Be sure the storage area is free of excessive humidity and dust.

1. Drain the fuel:

⚠ WARNING

Gasoline is flammable and explosive under certain conditions. Do not smoke or allow flames or sparks near the equipment while draining fuel.

- a. Drain the fuel tank.
- b. Turn the fuel valve to the OPEN position.
- c. Loosen the carburetor drain screw to drain the fuel into a suitable container.
- d. After draining, tighten the carburetor drain screw and turn the fuel valve to the OFF position.

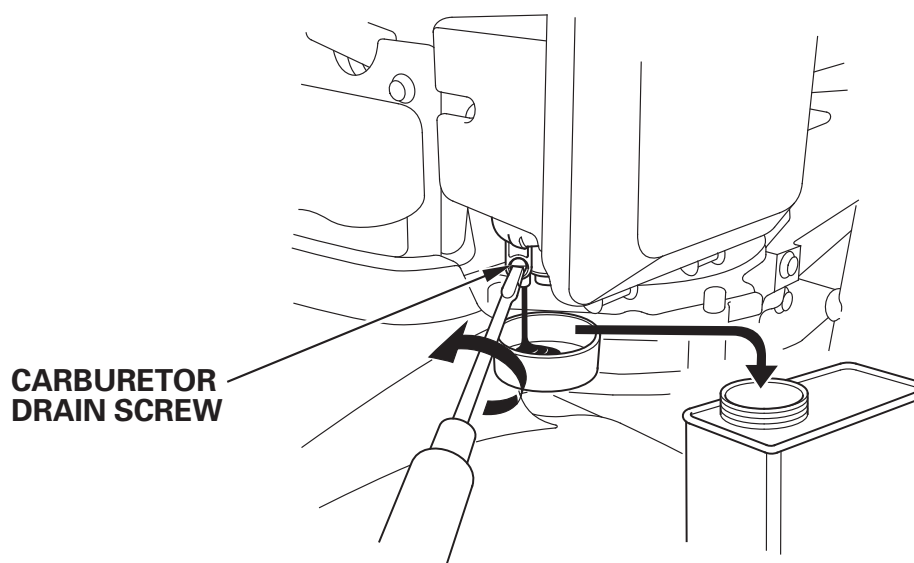

2. Change the engine oil (see page 36).
3. Clean the air cleaner (see page 37).
4. Pull the starter grip until resistance is felt. At this point, the intake and exhaust valves are closed and this will help to protect the engine from internal corrosion.
5. Pull the choke knob to the CLOSE position.
6. Coat areas that may rust with a light film of oil. Cover the tiller and store it on a level surface in a dust free area.

11. TROUBLESHOOTING

If there is any abnormal symptom with your tiller, see the following and troubleshoot your tiller accordingly. If the tiller is still abnormal, consult with your authorized Honda dealer. Do not try to disassemble the tiller by yourself.

Hard starting

Order	Check item	Condition/Remedy	Refer to page
1	Starting procedure	Start according to the starting procedure explained in the manual.	19 thru. 21
2	Fuel level	Add the gasoline.	15
3	Gasoline	If the gasoline is in the tank stale. Drain old gasoline and pour fresh gasoline.	56
4	Fuel used	Use the automotive unleaded regular gasoline.	15
5	Engine oil level	Add the engine oil to the specified level.	13
6	Air cleaner filter	Clean if contaminated. Replace if necessary.	37
7	Spark plug cap	Install the spark plug cap on the spark plug securely.	42
8	Spark plug	Wipe the spark plug and let it dry if it is wet and fouled.	41

Engine starts but then stalls.

Order	Check item	Condition/Remedy	Refer to page
1	Choke knob	Set the choke knob in the OPEN position.	21
2	Fuel valve	Set the fuel valve in the ON position.	19
3	Fuel level	Add gasoline.	15
4	Air cleaner filter	Clean if contaminated. Replace if necessary.	37

Rear wheels/tines turn without squeezing main clutch lever.

Order	Check item	Condition/Remedy	Refer to page
1	Main clutch cable	Adjust the main clutch cable properly.	44
2	Clutch oil level	Too much oil. Bring the level to the specified level.	39

Rear wheels do not turn by squeezing main clutch lever.

Order	Check item	Condition/Remedy	Refer to page
1	Gearshift lever position	Set the gearshift lever in the proper gear position (Forward or Reverse).	27 and 28
2	Wheel pin	Install the wheel pin and retaining pin securely if it is missing or out of position.	25
3	Main clutch cable	Adjust main clutch cable properly.	44
4	Clutch oil level	Bring the clutch oil level to the specified level.	39
5	Transmission oil level	Bring the transmission oil level to the specified level.	40

Rotary does not turn by squeezing main clutch lever.

Order	Check item	Condition/Remedy	Refer to page
1	Gearshift lever position	Set the gearshift lever in the proper gear position (Forward or Reverse).	27 and 28
2	Rotary pin	Install the rotary pin and retaining pin securely if it is missing or out of position.	50
3	Rotary	Remove the foreign material (stone, etc.) if it is caught in the rotary.	46 and 47
4	Main clutch cable	Adjust the main clutch cable properly.	44
5	Clutch oil level	Bring the clutch oil level to the specified level.	39
6	Transmission oil level	Bring the transmission oil level to the specified level.	40

Hard tilling/hard to move the tiller.

Order	Check item	Condition/Remedy	Refer to page
1	Front wheel	Set in the proper position.	23

Poor tilling performance.

Order	Check item	Condition/Remedy	Refer to page
1	Differential lock lever	Set the lever in the "LOCK" position.	31
2	Choke knob	Set the knob in the "OPEN" position.	21
3	Front wheel	Set in the proper position according to the tilling depth.	23
4	Rear wheel	Set the right and left rear wheels symmetrically.	25
5	Handlebar height	Set the handlebar in the proper position.	26
6	Bolts/nuts	Tighten securely.	18
7	Rotary	Remove the foreign material (grass, etc) if it is caught in the rotary.	46 and 47
8	Tines	Assemble the tines properly.	51 and 52
9	Main clutch cable	Adjust the main clutch cable properly.	44
10	Engine speed	If the engine speed is too low, move the throttle lever to increase the engine speed.	—
11	Throttle cable	Adjust the throttle lever free play properly.	43

Differential/differential lock does not function properly.

Order	Check item	Condition/Remedy	Refer to page
1	Differential lock lever	Operate properly.	31
2	Differential lock arm	Remove the foreign material (stone, etc.) if it is caught in the area.	See below
3	Differential lock cable	Adjust the differential lock lever freeplay properly.	45

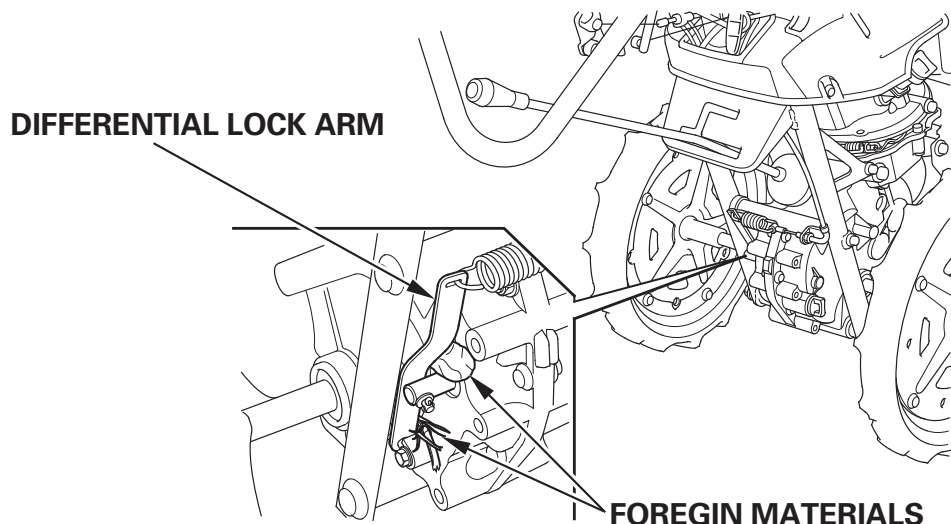

12. SPECIFICATIONS

Model	FF500
Power equipment description code	FANJ

Dimensions and weight

Model	FF500
Overall length	1,730 mm (68.1 in)
Overall width	585 mm (23.0 in)
Overall height	1,045 mm (41.1 in)
Dry mass [weight]	77 kg (170 lbs)

Engine

Model	GCV160
Engine type	4-stroke, overhead cam, single cylinder
Displacement	160 cm ³ (9.8 cu-in)
Bore × stroke	64.0 × 50.0 mm (2.52 × 1.97 in)
Cooling system	Forced air
Ignition system	Transistor magneto
Spark plug	BPR6ES (NGK)
Oil capacity	0.55 ℓ (0.58 US qt , 0.48 Imp qt)
Fuel tank capacity	1.7 ℓ (0.45 US gal , 0.37 Imp gal)
Compression ratio	8.5 : 1

Noise level and vibration

Sound pressure level (LpA) Tested by EN709	79 dB
Guaranteed sound power level (LWA) Tested by 2000/14/EC	93 dB
Vibration Tested by EN709	5.3 m/s ²

NOTE:

Specifications are subject to change without notice due to improvements.

13. MAJOR Honda DISTRIBUTOR ADDRESSES

For further information, please contact Honda Customer Information Centre at the following address or telephone number:

AUSTRIA

Honda Motor Europe (North)
Hondastraße 1
2351 Wiener Neudorf
Tel. : +43 (0)2236 690 0
Fax : +43 (0)2236 690 480
<http://www.honda.at>

BELGIUM

Honda Motor Europe (North)
Doornveld 180-184
1731 Zellik
Tel. : +32 2620 10 00
Fax : +32 2620 10 01
<http://www.honda.be>
✉ BH_PE@HONDA-EU.COM

BULGARIA

Kirov Ltd.
49 Tsaritsa Yoana blvd
1324 Sofia
Tel. : +359 2 93 30 892
Fax : +359 2 93 30 814
<http://www.kirov.net>
✉ honda@kirov.net

CANARY ISLANDS

Automocion Canarias S.A.
Carretera General del Sur, KM. 8,8
38107 Santa Cruz de Tenerife
Tel. : +34 (922) 620 617
Fax : +34 (922) 618 042
<http://www.aucasa.com>
✉ ventas@aucasa.com
✉ taller@aucasa.com

CROATIA

Hongoldonia d.o.o.
Jelkovecka Cesta 5
10360 Sesvete – Zagreb
Tel. : +385 1 2002053
Fax : +385 1 2020754
<http://www.hongoldonia.hr>

CYPRUS

Alexander Dimitriou & Sons Ltd.
162, Yiannos Kranidiotis Avenue
2235 Latsia, Nicosia
Tel. : +357 22 715 300
Fax : +357 22 715 400

CZECH REPUBLIC

BG Technik cs, a.s.
U Zavodiste 251/8
15900 Prague 5 - Velka Chuchle
Tel. : +420 2 838 70 850
Fax : +420 2 667 111 45
<http://www.honda-stroje.cz>

DENMARK

Tima Products A/S
Tårnfalkevej 16 - Postboks 511
2650 Hvidovre
Tel. : +45 36 34 25 50
Fax : +45 36 77 16 30
<http://www.tima.dk>

FINLAND

OY Brandt AB.
Tuupakantie 7B
01740 Vantaa
Tel. : +358 20 775 7200
Fax : +358 9 878 5276
<http://www.brandt.fi>

FRANCE

HONDA RELATIONS CLIENTS
TSA 80627
45146 St Jean de la Ruelle CEDEX
Tel. : 02 38 81 33 90
Fax : 02 38 81 33 91
<http://www.honda.fr>
✉ relationsclientele.produits-equipement@honda-eu.com

GERMANY

Honda Motor Europe (North) GmbH
Sprendlinger Landstraße 166
63069 Offenbach am Main
Tel. : +49 69 8300 60
Fax : +49 69 8300 65100
<http://www.honda.de>
✉ info@post.honda.de

GREECE

General Automotive Co S.A.
71 Leoforos Athinon
10173 Athens
Tel. : +30 210 349 7809
Fax : +30 210 346 7329
<http://www.honda.gr>
✉ info@saracakis.gr

HUNGARY

Mo.Tor.Pedo Co Ltd.

Kamaraerdei ut 3.

2040 Budaors

Tel. : +36 23 444 971

Fax : +36 23 444 972

<http://www.hondakisgepek.hu>

✉ info@hondakisgepek.hu

IRELAND

Two Wheels Ltd.

Crosslands Business Park

Ballymount Road

Dublin 12

Tel. : +353 01 460 2111

Fax : +353 01 456 6539

<http://www.hondaireland.ie>

✉ sales@hondaireland.ie

ITALY

Honda Italia Industriale S.p.A.

Via della Cecchignola, 5/7

00143 Roma

Tel. : +848 846 632

Fax : +39 065 4928 400

<http://www.hondaitalia.com>

✉ info.power@honda-eu.com

LATVIA

Bensons Auto

Kr.Valdemara Street 21, 646

office

Riga, 1010

Tel. : +371 7 808 333

Fax : +371 7 808 332

LITHUANIA

JP Motor Ltd

Kubiliaus str. 6

08234 Vilnius

Tel. : +370 5 276 5259

Fax : +370 5 276 5250

<http://www.hondapower.lt>

MALTA

The Associated Motors

Company Ltd.

New Street in San Gwakkın

Road

Mriehel Bypass, Mriehel QRM

17

Tel. : +356 21 498 561

Fax : +356 21 480 150

NETHERLANDS

Honda Motor Europe (North)

Afd. Power Equipment-

Capronilaan 1

1119 NN Schiphol-Rijk

Tel. : +31 20 7070000

Fax : +31 20 7070001

<http://www.honda.nl>

NORWAY

Berema AS

P.O. Box 454

1401 Ski

Tel. : +47 64 86 05 00

Fax : +47 64 86 05 49

<http://www.berema.no>

✉ berema@berema.no

POLAND

Aries Power Equipment Sp. z

o.o.

ul. Wroclawska 25A

01-493 Warszawa

Tel. : +48 (22) 861 43 01

Fax : +48 (22) 861 43 02

<http://www.hondapower.pl>

✉ info@hondapower.pl

PORTUGAL

Honda Portugal, S.A.

Abrunheira

2714-506 Sintra

Tel. : +351 21 915 53 33

Fax : +351 21 915 23 54

<http://www.honda.pt>

✉ honda.produtos@honda-eu.com

REPUBLIC OF BELARUS

Scanlink Ltd.

Kozlova Drive, 9

220037 Minsk

Tel. : +375 172 999090

Fax : +375 172 999900

ROMANIA

Hit Power Motor Srl

Calea Giulesti N° 6-8 Sector 6

060274 Bucuresti

Tel. : +40 21 637 04 58

Fax : +40 21 637 04 78

<http://www.honda.ro>

✉ hit_power@honda.ro

RUSSIA

Honda Motor Rus Llc

42/1-2, Bolshaya Yakimanka st.

117049, Moscow

Tel. : +74 95 745 20 80

Fax : +74 95 745 20 81

<http://www.honda.co.ru>

SERBIA & MONTENEGRO

Bazis Grupa d.o.o.

Grcica Milenka 39

11000 Belgrade

Tel. : +381 11 3820 300

Fax : +381 11 3820 301

<http://www.hondasrbija.co.yu>

SLOVAKIA REPUBLIC

Honda Slovakia, spol. s r.o.

Prievozska 6 - 821 09

Bratislava

Slovak Republic

Tel. : +421 2 32131112

Fax : +421 2 32131111

<http://www.honda.sk>

SLOVENIA

AS Domzale Moto Center D.O.

O.

Blatnica 3A

1236 Trzin

Tel. : +386 1 562 22 42

Fax : +386 1 562 37 05

<http://www.as-domzale-motoc.si>

SPAIN

Greens Power Products, S.L.

Avda. Ramon Ciurans, 2

08530 La Garriga - Barcelona

Tel. : +34 3 860 50 25

Fax : +34 3 871 81 80

<http://www.hondaencasa.com>

SWEDEN

Honda Nordic AB

Box 50583 - Västkustvägen 17

120215 Malmö

Tel. : +46 (0)40 600 23 00

Fax : +46 (0)40 600 23 19

<http://www.honda.se>

✉ hpesinfo@honda-eu.com

SWITZERLAND

Honda Suisse S.A.

10, Route des Moulières

1214 Vemier - Genève

Tel. : +41 (0)22 939 09 09

Fax : +41 (0)22 939 09 97

<http://www.honda.ch>

TURKEY

Anadolu Motor Uretim Ve

Pazarlama AS (ANPA)

Esentepe mah. Anadolu

Cad. No: 5

Kartal 34870 Istanbul

Tel. : +90 216 389 59 60

Fax : +90 216 353 31 98

<http://anadolumotor.com.tr>

✉ antor@antor.com.tr

UKRAINE

Honda Ukraine LLc

101 Volodymyrska Str. - Build. 2

Kiev 01033

Tel. : +380 44 390 1414

Fax : +380 44 390 1410

<http://www.honda.ua>

UNITED KINGDOM

Honda (ULC) Power

Equipment

470 London Road

Slough - Berkshire, SL3 8QY

Tel. : +44 (0)845 200 8000

Fax : +44 (0)1 753 590 732

<http://www.honda.co.uk>

✉ customer.service@honda-eu.com

honda-eu.com

MEMO

MEMO

MEMO

HONDA

The Power of Dreams

36V24603
00X36-V24-6030

© Honda Motor Co., Ltd. 2004
 英 仏 独 西 〇 (HC) 500.2008.07
Printed in Japan